

PHILIPPINE BIDDING DOCUMENTS

Government of the
Republic of the Philippines

Procurement of **INFRASTRUCTURE PROJECTS**

**First Edition
May 2025**

Preface

These Philippine Bidding Documents (PBD) for the procurement of Infrastructure Projects (hereinafter referred to also as the “Works”) through [*Competitive Bidding, Limited Source Bidding, or Competitive Dialogue*¹] have been prepared by the Government of the Philippines (GoP) for use by all branches, agencies, departments, bureaus, offices, or instrumentalities of the Government, including government-owned and/or -controlled corporations (GOCC), government financial institutions (GFI), state universities and colleges (SUC), local government units (LGU), and autonomous regional government. The procedures and practices presented in this document have been developed through broad experience, and are for mandatory² use in projects that are financed in whole or in part by the GoP or any foreign government/foreign or international financing institution in accordance with the provisions of the Implementing Rules and Regulations (IRR) of Republic Act No. 12009 (RA No. 12009).

This PBD is intended as a model for admeasurements (unit prices or unit rates in a bill of quantities) types of contract, which are the most common in Works contracting.

The Bidding Documents shall clearly and adequately define, among others: (a) the objectives, scope, and expected outputs and/or results of the proposed contract; (b) the eligibility requirements of Bidders; (c) the expected contract duration; and (d) the obligations, duties, and/or functions of the winning bidder.

In order to simplify the preparation of the Bidding Documents for each procurement, the PBD groups the provisions that are intended to be used unchanged in Section II. Instructions to Bidders (ITB) and in Section IV. General Conditions of Contract (GCC). Data and provisions specific to each procurement and contract should be included in Section III. Bid Data Sheet (BDS); Section V. Special Conditions of Contract (SCC); Section VI. Specifications; Section VII. Drawings; and Section VIII. Bill of Quantities. The forms to be used are provided in Section IX. Philippine Bidding Documents Related Forms.

Prudence must be exercised to check the relevance of the provisions of the PBD against the requirements of the specific Works to be procured. In addition, each Section is prepared with notes intended only as information for the Procuring Entity or the person drafting the Bidding Documents. They shall not be included in the final documents, except for the notes introducing Section IX. Philippine Bidding Documents Related Forms, where the information is useful for the Bidder. The following general directions should be observed when using the documents:

- a) All the documents listed in the Table of Contents are normally required for the procurement of Infrastructure Projects. However, they should be adapted as necessary to the circumstances of the particular Project.
- b) Specific details, such as the “name of the Procuring Entity” and “address for proposal submission,” should be furnished in the BDS and SCC. The final documents should contain neither blank spaces nor options.
- c) This Preface and the footnotes, or notes in italics included in the Invitation to Bid, BDS, SCC, Specifications, Drawings, and Bill of Quantities are not part of the text of the final document, although they contain instructions that the Procuring Entity should

¹ For Second Stage of Competitive Dialogue under Section 29.4.2 of IRR of RA No. 12009.

² Unless the Treaty or International or Executive Agreement expressly provides use of foreign government/foreign or international financing institution procurement guidelines.

strictly follow. The Bidding Documents should not contain footnotes except Section IX. Philippine Bidding Documents Related Forms since these provide important guidance to Bidders.

- d) The cover page should be modified as required to identify the Bidding Documents and date of issue.
- e) The Project title page should be modified as required to identify the Project title and number, name and address of the Procuring Entity.
- f) If modifications must be made to the bidding requirements, they can be presented in the BDS. Modifications for specific Project or Contract details should be provided in the SCC as amendments to the Conditions of Contract. For easy completion, whenever reference has to be made to specific clauses in the BDS or SCC, these terms shall be printed in bold type face on Section II. Instructions to Bidders, and Section IV. General Conditions of Contract, respectively. To facilitate easy reference and completion, clauses from the BDS and SCC shall appear in bold type face in Sections II and IV, respectively.



**PROVINCIAL GOVERNMENT OF CAMARINES NORTE
DAET CAMARINES NORTE**

**Procurement of
INFRASTRUCTURE PROJECTS:**

**CONSTRUCTION OF WATER
SYSTEM**

Brgy. Hinipaan, Mercedes, Camarines Norte

ITB-2026-060

June 9, 2026

TABLE OF CONTENTS

Glossary of Acronyms, Terms, and Abbreviations.....	6
Definition of Terms.....	8
Section I. Invitation to Bid	11
Section II. Instructions to Bidders	12
A. General	17
B. Contents of Bidding Documents.....	24
C. Preparation of Bids	25
D. Submission and Opening of Bids	32
E. Evaluation and Comparison of Bids	34
F. Award of Contract.....	39
Section III. Bid Data Sheet	42
Section IV. General Conditions of Contract	49
Section V. Special Conditions of Contract.....	78
Section VI. Specifications	79
Section VII. Drawings	117
Section VIII. Bill of Quantities.....	118
Section IX. Philippine Bidding Documents Related Forms.....	120
Section X. Checklist of Technical and Financial Documents	138

Glossary of Acronyms, Terms, and Abbreviations

ABC – Approved Budget for the Contract.

ADR – Alternative Dispute Resolution.

ARCC – Allowable Range of Contract Cost.

BAC – Bids and Awards Committee.

BIR – Bureau of Internal Revenue.

BSP – Bangko Sentral ng Pilipinas.

CDA – Cooperative Development Authority.

COS – Contract of Service.

CPI – Consumer Price Index.

DOLE – Department of Labor and Employment.

DTI – Department of Trade and Industry.

GCC - General Conditions of Contract.

GFI – Government Financial Institution.

GOCC – Government-Owned and/or –Controlled Corporation.

GoP – Government of the Philippines.

GPPB – Government Procurement Policy Board.

HoPE – Head of Procuring Entity.

JO – Job Order.

IRR – Implementing Rules and Regulations.

ITB – Instructions to Bidders.

LCB- Lowest Calculated Bid.

LCRB – Lowest Calculated Responsive Bid.

LGUs – Local Government Units.

LoC – Line of Credit

MAB – Most Advantageous Bid.

MARB – Most Advantageous Responsive Bid.

MEARB – Most Economically Advantageous Responsive Bid.

MYCA – Multi-Year Contracting Authority.

NFCC – Net Financial Contracting Capacity.

NGA – National Government Agency.

PCAB – Philippine Contractors Accreditation Board.

PhilGEPS - Philippine Government Electronic Procurement System.

PSA – Philippine Statistics Authority.

RA No. – Republic Act Number.

SARB – Single Advantageous and Responsive Bid.

SCC - Special Conditions of Contract.

SCRB – Single Calculated and Responsive Bid.

SEARB – Single Economically Advantageous Responsive Bid.

SEC – Securities and Exchange Commission.

SLCC – Single Largest Completed Contract.

SRRB – Single Rated and Responsive Bid.

UN – United Nations.

Definition of Terms

Bid – a signed offer, proposal, or quotation submitted by a supplier, manufacturer, distributor, contractor, consultant, or service provider in response to the requirements of the Procuring Entity as stated in the Bidding Documents. (IRR of RA No. 12009, Section 5[c]).

Bidder – a supplier, manufacturer, distributor, contractor, consultant, and service provider, whether public or private, who submits a Bid in response to the requirements of the Procuring Entity as stated in the Bidding Documents. (IRR of RA No. 12009, Section 5[d]).

Bidding Documents – the documents issued by the Procuring Entity as the basis for Bids, furnishing all information necessary to prospective bidder to prepare a Bid for the Goods, Infrastructure Projects, and Consulting Services required by the Procuring Entity. (IRR of RA No. 12009, Section 5[e])

Bill of Quantities – a list of the specific items of the Work and their corresponding unit prices, lump sums, and/or provisional sums.

Consulting Services – services for Infrastructure Projects and other types of projects or activities of the government requiring adequate external technical and professional expertise that are beyond the capability or capacity of the government to undertake such as, but not limited to: (i) advisory and review services; (ii) pre-investment or feasibility studies; (iii) design; (iv) construction supervision; (v) management and related services; and (vi) other technical services or special studies. (IRR of RA No. 12009, Section 5[i]).

Contract – the agreement entered into between the Procuring Entity and the Contractor to execute, complete, and maintain the Works and as recorded in the Contract Form signed by the parties, including all attachments and appendices thereto and all documents incorporated by reference therein.

Contract Price – the price stated in the Notice of Award and thereafter to be paid by the Procuring Entity to the Contractor for the execution of the Works in accordance with this Contract.

Contract Time Extension (CTE) – the allowable period for the Contractor to complete the Works in addition to the original Completion Date stated in this Contract.

Contractor – a natural or juridical entity whose proposal was accepted by the Procuring Entity and to whom the Contract to execute the Work was awarded. Contractor as used in these Bidding Documents may likewise refer to a supplier, distributor, manufacturer, or consultant.

Days – refers to calendar days; months to calendar months.

Dayworks – varied work inputs subject to payment on a time basis for the Contractor's employees and Equipment, in addition to payments for associated Materials and Plant.

Defect – any part of the Works not completed in accordance with the Contract.

Defects Liability Certificate – the certificate issued by the Procuring Entity upon correction of defects by the Contractor.

Defects Liability Period – the one (1) year period between contract completion and final acceptance within which the Contractor assumes the responsibility to undertake the repair of any damage to the Works at its own expense.

Drawings – graphical presentations of the Works. They include all supplementary details, shop drawings, calculations, and other information provided or approved for the execution of this Contract.

Effective Date of the Contract – the date indicated in the contract. However, the Contractor shall commence performance of its obligations only upon receipt of the Notice to Proceed.

Foreign-funded Procurement or Foreign-Assisted Project – refers to the acquisition of Goods, Consulting Services, and the contracting for Infrastructure Projects by the Government of the Philippines which are wholly or partly funded by foreign loans or grants pursuant to a Treaty or International or Executive Agreement.

Funding Source – Organization named in the SCC.

Goods – refer to (i) all items, supplies, and materials, whether in the nature of equipment, furniture, stationery, materials for construction, or personal property of any kind, needed in the transaction of public businesses or in the pursuit of any government undertaking, project or activity; or (ii) general support services which pertain to all types of services except Consulting Services and Infrastructure Projects, such as the repair and maintenance of equipment and furniture, as well as trucking, hauling, janitorial, security, and related or analogous services. Personnel Services or individual COS or JO engagements do not fall under this definition; (IRR of RA No. 12009, Section 5[n]).

Infrastructure Projects – include the construction, improvement, rehabilitation, demolition, repair, restoration, or maintenance of roads and bridges, railways, airports, seaports, communication facilities, civil works components of information technology projects, irrigation, flood control and drainage, water supply, sanitation, sewerage and solid waste management systems, shore protection, energy/power and electrification facilities, national buildings, school buildings, hospital buildings, and other related construction projects of the government. Also referred to as “civil works” or “works;” (IRR of RA No. 12009, Section 5[r]).

Lot – refers to one or more infrastructure projects that are grouped or bundled together based on factors, such as scope, location, or other relevant parameters, as determined by the End-User or Implementing Unit of the Procuring Entity. Each lot is distinct within the project and may be awarded as a separate contract.

MARB – refers to the award criteria in the procurement of Infrastructure where the considerations for the award of contract are the eligibility of the bidder, the responsiveness of its bid to the technical requirements, and the most advantageous bid in reference to the highest rated offer based on the quality component of the bid.

Materials – refer to all supplies, including consumables, used by the Contractor for incorporation in the Works.

MEARB – refers to the award criteria in the procurement of Infrastructure where the considerations for the award of contract are the eligibility of the bidder, the responsiveness of its bid to the technical requirements, and the determination of the most economically advantageous bid in reference to the quality-price ratio allocated to the technical and financial components of the bid.

Notice to Proceed – refers to a written notice issued by the Procuring Entity to the Contractor requiring the latter to begin the commencement of the work not later than a specified or determinable date.

Online submission – pertains to the submission of the bid for Infrastructure Projects and the bid envelopes containing the technical and financial components of the bid through electronic means or through the electronic bidding facility of the PhilGEPS, once available.

Permanent Works – refer to all permanent structures and all other project features and facilities required to be constructed and completed in accordance with this Contract which shall be delivered to the Procuring Entity, and which shall remain at the Site after the removal of all Temporary Works.

Plant – refers to the machinery, apparatus, and the like intended to form an integral part of the Permanent Works.

Procuring Entity - the organization acquiring the Infrastructure Project, as named in the SCC.

Project – refers to a specific or identified procurement covering Goods, Infrastructure Projects or Consulting Services. A Procurement Project shall be described, detailed, and scheduled in the Project Procurement Management Plan prepared by the agency which shall be consolidated in the Procuring Entity's Annual Procurement Plan.

Program of Work – refers to the big-picture plan and comprehensive schedule that details construction-related tasks to ensure the timely and efficient delivery of the project.

Site Investigation Reports – refers to those that were included in the Bidding Documents and are factual and interpretative reports about the surface and subsurface conditions at the Site.

Slippage – refers to a delay in work execution occurring when actual accomplishment falls below the target as measured by the difference between the scheduled and actual accomplishment of the Work by the Contractor as established from the work schedule. This is actually described as a percentage of the whole Works.

Simple Infrastructure Projects – refers to construction, improvement, rehabilitation, demolition, repair, restoration, or maintenance of structures, technical facilities and systems with an Approved Budget for the Contract (ABC) not exceeding Ten Million Pesos (PhP 10,000,000.00) built at the community level for the sustenance of lives and livelihoods of the population living in a community and built according to the needs and aspirations of the community population.

Verified Report – the report submitted by the Implementing Unit to the HoPE setting forth its findings as to the existence of grounds or causes for termination and explicitly stating its recommendation for the issuance of a Notice to Terminate.

Section I. Invitation to Bid



Republic of the Philippines
PROVINCE OF CAMARINES NORTE
BIDS AND AWARDS COMMITTEE



INVITATION TO BID
for the
Construction of Water System,
Brgy. Hinipaan, Mercedes, Camarines Norte

1. The *Provincial Government of Camarines Norte*, through the *20% Development Fund AB2026* intends to apply the sum of *Three Million Nine Hundred Ninety-Five Thousand Nine Hundred Twenty-Four Pesos and Eighty-Seven Centavos (P3,995,924.87)* being the Approved Budget for the Contract (ABC) to payments under the contract for the *Construction of Water System, Brgy. Hinipaan, Mercedes, Camarines Norte*. Bids received in excess of the ABC shall be automatically rejected at bid opening.
2. The *Provincial Government of Camarines Norte* now invites bids for the *Rehab. Of Water Source, Installation of 3150LM Transmission Pipe and Installation of 1 unit tapstand*. Completion of the Works is required *90 CD*. Bidders should have completed a contract similar to the Project. The description of an eligible bidder is contained in the Bidding Documents, particularly, in Section II (*Instructions to Bidders*).
3. Bidding will be conducted through competitive bidding procedures using non-discretionary "pass/fail" criterion as specified in the IRR, otherwise known as the "New Government Procurement Act (NGPA)."

Bidding is restricted to Filipino citizens/sole proprietorships, cooperatives, and partnerships or organizations with at least sixty percent (60%) interest or outstanding capital stock belonging to citizens of the Philippines.
4. Interested bidders may obtain further information from the *Provincial Government of Camarines Norte* and inspect the Bidding Documents at the address given below from *8:00a.m. to 5:00p.m., Monday to Friday, except Holidays*.
5. A complete set of Bidding Documents may be acquired by interested bidders on *June 9, 2026 – June 30, 2026* at the *Provincial Capitol Building, Daet, Camarines Norte* and upon payment of the applicable fee for the Bidding Documents, pursuant to the latest Guidelines issued by the GPPB, in the amount of *Five Thousand Pesos (P5,000.00)*.

It may also be downloaded free of charge from the website of the Philippine Government Electronic Procurement System (PhilGEPS) and the website of the Procuring Entity, provided that bidders shall pay the applicable fee for the Bidding Documents not later than the submission of their bids.
6. The *Provincial Government of Camarines Norte* will hold a Pre-Bid Conference on *June 18, 2026 2:00p.m.* at the *Provincial Capitol Building, Daet, Camarines Norte*, which shall be open to prospective bidders.
7. Bids must be duly received by the Bids and Awards Committee (BAC) Secretariat **through manual submission** at the address below on or before *June 30, 2026 at 1:30p.m.* Late bids shall not be accepted.

8. All bids must be accompanied by a Bid Security in any of the acceptable forms and in the amount stated in ITB Clause 16.
9. Bid opening shall be on **June 30, 2026, 2:00 p.m. onwards** at the **Provincial Capitol Building, Daet, Camarines Norte**. Bids will be opened in the presence of the bidders' representatives who choose to attend the activity, provided that an Authorization Letter shall be submitted to the BAC on or before the scheduled opening of bids. **Only one (1) representative for each Bidder may physically attend the bid opening.**
10. The Bid Evaluation and Award Criteria are **Lowest Calculated Bid (LCB)** and **Lowest Calculated and Responsive Bid (LCRB)**, respectively.
11. The **Provincial Government of Camarines Norte** reserves the right to reject any and all bids, declare a failure of bidding, or not award the contract at any time prior to contract award in accordance with Section 70 of R.A. No. 12009, without thereby incurring any liability to the affected bidder or bidders.
12. For further information, please refer to:
ENGR. HAROLD R. GESTIADA, EnP
P.A.B.E. / Head, BAC Secretariat
Bids and Awards Committee Office,
Provincial Capitol Bldg., Daet, Camarines Norte
baccamnorte2025@gmail.com

13. You may visit the website:
For downloading of Bidding Documents:
Philippine Government Electronic Procurement System (PhilGEPS)
Provincial Government of Camarines Norte Official Website (www.camsnorte.com)

MAXIMO P. MAGANA, JR.
Provincial Assessor / BAC Chairperson

Section II. Instructions to Bidders

TABLE OF CONTENTS

A. GENERAL	17
1. Scope of Bid	17
2. Source of Funds	17
3. Corrupt, Fraudulent, Collusive, Coercive, and Obstructive Practices.....	17
4. Conflict of Interest	18
5. Eligible Bidders	19
6. Bidder’s Responsibilities.....	21
7. Origin of Goods and Services.....	23
8. Subcontracts	23
B. CONTENTS OF BIDDING DOCUMENTS	24
9. Pre-Bid Conference.....	24
10. Clarification and Amendment of Bidding Documents.....	24
C. PREPARATION OF BIDS	25
11. Language of Bids	25
12. Documents Comprising the Bid: Technical and Financial Components.....	25
13. Bid Prices	27
14. Bid Currencies	27
15. Bid Validity	27
16. Bid Security	27
17. Format and Signing of Bids.....	31
18. Sealing and Marking of Bids	31
D. SUBMISSION AND OPENING OF BIDS	32
19. Deadline for Submission of Bids	32
20. Late Bids	32
21. Modification and Withdrawal of Bids.....	32
22. Opening and Preliminary Examination of Bids	33
E. EVALUATION AND COMPARISON OF BIDS	34
23. Process to be Confidential.....	34
24. Clarification of Bids.....	34
25. Detailed Evaluation and Comparison of Bids	34
26. Post-Qualification	36

27.	Reservation Clause	38
F.	AWARD OF CONTRACT.....	39
28.	Contract Award.....	39
29.	Signing of the Contract	39
30.	Performance Security	40
31.	Notice to Proceed.....	41
32.	Protest Mechanism.....	41

A. General

1) Scope of Bid

- 1.1 The Procuring Entity, **Provincial Government of Camarines Norte**, invites Bids for the **Construction of Water System, Brgy. Hinipaan, Mercedes, Camarines Norte**, with Project Identification Number **ITB-2026-060**.

The Procurement Project (referred to herein as “Project”) is for the construction of Works, as described in Section VI (Specifications).

- 1.2 The winning Bidder will be expected to complete the Works by the intended completion date specified in **SCC** Clause 1.1.

2) Source of Funds

The Procuring Entity has a budget or received funds from the Funding Source named in the **BDS**, and in the amount indicated in the **BDS**. It intends to apply part of the funds received for this Project to cover eligible payments under the contract.

3) Corrupt, Fraudulent, Collusive, Coercive, and Obstructive Practices

- 3.1 Unless otherwise specified in the **BDS**, the Procuring Entity, as well as Bidders and Contractors, shall observe the highest standard of ethics during the procurement and execution of the contract. In pursuance of this policy, the Procuring Entity:

- a) defines, for purposes of this provision, the following terms under existing laws, rules, and regulations:
- i) "corrupt practice" means an act by which officials in the public or private sectors improperly and unlawfully enrich themselves, others, or induce others to do so, by misusing the position in which they are placed, and includes the offering, giving, receiving, or soliciting of anything of value to influence the action of any such official in the procurement process or in contract execution; entering, on behalf of the government, into any contract or transaction manifestly and grossly disadvantageous to the same, whether or not the public officer profited or will profit thereby, and similar acts as provided in RA No. 3019.
 - ii) "fraudulent practice" means a misrepresentation of facts for purposes of influencing a procurement process or the execution of a contract to the detriment of the Procuring Entity, which includes collusive practices among Bidders (prior to or after bid submission) designed to establish bid prices at artificial, non-competitive levels and to deprive the Procuring Entity of the benefits of free and open competition.
 - iii) “collusive practices” means a scheme or arrangement between two or more Bidders, with or without the knowledge of the Procuring Entity, designed to establish bid prices at artificial, non-competitive levels.
 - iv) “coercive practices” means harming or threatening to harm, directly or indirectly, persons, or their property to influence their participation in a procurement process, or affect the execution of a contract;
 - v) “obstructive practice” is

- a) deliberately destroying, falsifying, altering or concealing of evidence material to an administrative proceedings or investigation or making false statements to investigators in order to materially impede an administrative proceedings or investigation of the Procuring Entity or any foreign government/foreign or international financing institution relative to allegations of a corrupt, fraudulent, coercive or collusive practice; and/or threatening, harassing or intimidating any party to prevent the latter from disclosing its knowledge of matters relevant to the administrative proceedings or from pursuing such proceedings or investigation; or
 - b) acts intended to materially impede the exercise of the inspection and audit rights of the Procuring Entity or any foreign government/foreign or international financing institution herein.
 - b) Undertakes to reject a proposal for award upon *prima facie* determination that the Bidder recommended for award has engaged in any of the prohibited practices mentioned in this Clause for purposes of competing for the contract.
- 3.2 Further, the Procuring Entity will seek to impose the maximum civil, administrative, and/or criminal penalties available under the applicable laws on individuals and organizations deemed to be involved in any of the practices mentioned in **ITB** Clause 4.
- 3.3 Furthermore, the Funding Source and the Procuring Entity reserve the right to inspect and audit records and accounts of a Bidder or Contractor in the bidding for and performance of a contract themselves or through independent auditors as reflected in the **GCC** Clause 36.

4) Conflict of Interest

- 4.1 All Bidders found to have conflicting interests shall be disqualified to participate in the procurement at hand, without prejudice to the imposition of appropriate administrative, civil, and criminal sanctions. A Bidder may be considered to have conflicting interests with another Bidder in any of the events described in paragraphs (a) through (c) and a general conflict of interest in any of the circumstances set out in paragraphs (d) through (f) below:
 - a) A Bidder has controlling shareholders or beneficial owners in common with another Bidder;
 - b) A Bidder receives or has received any direct or indirect subsidy from any other Bidder;
 - c) A bidder has the same legally authorized representative as that of another Bidder for purposes of this Bid;
 - d) A bidder has a relationship, directly or through third parties, that puts them in a position to have access to information about or influence on the bid of another Bidder or influence the decisions of the Procuring Entity regarding this bidding process. This may include a firm or an organization that lends, or temporarily seconds, its personnel to firms or organizations that are engaged in consulting services for the preparation related to procurement for or implementation of

the project if the personnel would be involved in any capacity on the same project;

- e) A bidder who participated as a consultant in the preparation of the design or technical specifications of the goods and related services that are the subject of the bid; or
 - f) A bidder who lends, or temporarily seconds, its personnel to firms or organizations which are engaged in consulting services for the preparation related to procurement for or implementation of the project, if the personnel would be involved in any capacity on the same project.
- 4.2 All Bidding Documents shall be accompanied by an Omnibus Sworn Statement of the Bidder that it is not related, by consanguinity or affinity up to the third civil degree, to the HoPE, Procurement Agent (if engaged), the head of the Project Management Office (PMO), the End-User or Implementing Unit or any members of the Bids and Awards Committee (BAC), Technical Working Group (TWG), and BAC Secretariat.³
- 4.3 The Bidder shall also disclose the ultimate beneficial ownership of the entity it represents. Failure to comply shall be a ground for the automatic disqualification of the bid in consonance with Section 59 of the IRR. For this reason, relationship to the aforementioned persons within the third civil degree of consanguinity or affinity shall automatically disqualify the Bidder from participating in the procurement of contracts of the Procuring Entity notwithstanding the act of such persons inhibiting themselves from the procurement process. This Clause shall apply to the following persons and affiliates:
- a) In the case of individuals or sole proprietorships, to the Bidders and their spouses;
 - b) In the case of partnerships, to the partnership itself and its partners;
 - c) In the case of cooperatives, to the cooperative itself and members of the board of directors, general manager or chief executive officer;
 - d) In the case of a partnership, joint venture, or consortium, to the entity itself, its members or partners, as well as any person or entity that is a member of a blacklisted partnership, joint venture, or consortium; and
 - e) In the case of corporations, a single stockholder, together with their relatives up to the third civil degree of consanguinity or affinity, and their assignees, holding at least twenty percent (20%) of the shares therein, its chairperson and president, shall be blacklisted after they have been determined to hold the same controlling interest in a previously blacklisted corporation or in two corporations that have been blacklisted; the corporations of which they are part shall also be blacklisted.

5) Eligible Bidders

³ Section 81.1 of the IRR.

- 5.1 Only Bids found to be legally, technically, and financially eligible will be evaluated. For procurement of Infrastructure Projects, the following persons shall be eligible to participate in this bidding:
- a) Duly licensed Filipino citizens or sole proprietorships;
 - b) Partnerships duly organized under the laws of the Philippines and of which at least sixty percent (60%) of the interest belongs to citizens of the Philippines;
 - c) Corporations duly organized under the laws of the Philippines, and of which at least sixty percent (60%) of the outstanding capital stock belongs to citizens of the Philippines;
 - d) Cooperatives duly organized under the laws of the Philippines; and
 - e) Persons or entities forming themselves into a Joint Venture (JV), i.e., a group of two (2) or more persons or entities that intend to be jointly and severally responsible or liable for a particular contract; Provided, however, that in accordance with relevant laws, rules, and regulations, Filipino ownership or interest of the joint venture concerned shall be at least sixty percent (60%); Provided, further, that joint ventures in which Filipino ownership or interest is less than sixty percent (60%) may be eligible where the structures to be built require the application of techniques or technologies which are not adequately possessed by a person or entity meeting the sixty percent (60%) Filipino ownership requirement; Provided, furthermore, that in the latter case, Filipino ownership or interest shall not be less than twenty-five percent (25%). For this purpose, Filipino ownership or interest shall be based on the contributions of each of the member of the joint venture as specified in their Joint Venture Agreement (JVA); Provided, finally, that the primary purpose of each member of the joint venture must be similar or related to the requirement of the project to be bid out.
- 5.2 The Procuring Entity may also invite foreign bidders when provided for under any Treaty or International or Executive Agreement as specified in the **BDS**.
- 5.3 In accordance with RA No. 4566 or the “Contractors' License Law” as amended by RA No. 11711 or “An Act Further Amending Republic Act No. 4566”, the persons or entities enumerated in Section 52 of the IRR may participate in the procurement of Infrastructure Projects if it has been issued a license by the Philippine Contractors Accreditation Board (PCAB) to engage or act as a contractor.
- 5.4 The Bidder must have completed an SLCC that is similar to the procurement project to be bid, and whose value must be equivalent to at least fifty percent (50%) of the ABC, adjusted to current prices using the Philippine Statistics Authority (PSA) consumer price indices; Provided, that any change to the fifty percent (50%) requirement may be allowed, subject to the recommendation of the Procuring Entity, which shall be submitted to the GPPB for consideration; Provided, further, that contractors under Small A and Small B categories without similar experience on the procurement project to be bid may be allowed to bid if the cost of such contract is not more than the Allowable Range of Contract Cost of their registration based on the guidelines as prescribed by the PCAB.

For foreign-funded procurement, the GoP and the foreign government, or foreign or international financing institution may agree on another track record requirement, as specified in the **BDS**.

Moreover, a contract shall be considered similar to the procurement project if it has the same major categories of work. The Procuring Entity may clarify in the Bidding Documents what is regarded as major categories of work, guided by the principle of proportionality and Fit-for-Purpose approach.

- 5.5 The SLCC shall be supported by an Owner's Certificate of Final Acceptance issued by the project owner other than the Contractor, or a final rating of at least Satisfactory in the Constructors Performance Evaluation System (CPES), or a similar performance and monitoring system. In the case of contracts with the private sector, an equivalent document shall be submitted.
- 5.6 The computation of a bidder's NFCC must be at least equal to the ABC to be bid, calculated as follows:

NFCC = [(Current assets minus current liabilities) (15)] minus the value of all outstanding or uncompleted portions of the projects under ongoing contracts, including awarded contracts yet to be started, coinciding with the procurement project to be bid; Provided, That a different formula may be adopted subject to the recommendation of the Procuring Entity, which shall be submitted to the GPPB for consideration.

The value of the domestic bidder's current assets and current liabilities shall be based on the latest AFS submitted to the BIR.

For purposes of computing the foreign bidders' NFCC, the value of the current assets and current liabilities shall be based on their latest AFS prepared in accordance with international financial reporting standards.

6) Bidder's Responsibilities

- 6.1 The Bidder or its duly authorized representative shall submit a sworn statement in the form prescribed in Section IX. Philippine Bidding Documents Related Forms as required in ITB Clause 12.1(h)(iv).
- 6.2 Before submitting their bids, the Bidders are deemed to be knowledgeable of all existing laws, decrees, ordinances, acts and regulations of the Philippines which may affect this Project in any way.
- 6.3 The Bidder undertook the following responsibilities:
 - a) Took steps to carefully examine and ensure full understanding and comprehension of the Bidding Document, its requirements, clauses, and provisions;
 - b) Acknowledged all conditions, local or otherwise, affecting the implementation of the contract;
 - c) Made an estimate of the facilities available and needed for the contract to be bid, if any;
 - d) Complied with its responsibility to inquire or secure Supplemental Bid Bulletin(s);
 - e) Ensured that it is not "blacklisted" or barred from bidding by the Government of the Philippines (GoP) or any of its agencies, offices, corporations, or LGUs,

including foreign government, or foreign/ international financing institutions whose blacklisting rules have been recognized by the GPPB; by itself or by reason of its relation, membership, association, affiliation, or controlling interest with another blacklisted person or entity;

- f) Ensured that each of the documents submitted in satisfaction of the bidding requirements is an authentic copy of the original, complete, and that all statements and information provided therein are true and correct;
- g) Authorized the HoPE or its duly authorized representative/s to verify all the documents submitted;
- h) Ensured that the signatory is the duly authorized representative of the Bidder, and granted full power and authority to do, execute and perform any and all acts necessary to participate, submit the bid, to sign, and execute the ensuing contract, accompanied by the duly notarized Special Power of Attorney, Board or Partnership Resolution, or Secretary's Certificate, whichever is applicable;
- i) Complied with the disclosure provision under Section 81 and 82 of RA No. 12009 and its IRR in relation to other provisions of RA No. 3019;
- j) Complied with existing labor laws and standards. Moreover, the Bidder undertakes to:

- i) Ensure the entitlement of workers to wages, hours of work, safety and health and other prevailing conditions of work as established by national laws, rules and regulations; or Collective Bargaining Agreement (CBA) or arbitration award, if and when applicable.

In case there is a finding by the Procuring Entity or the Department of Labor and Employment (DOLE) of underpayment or non-payment of workers' wages and wage-related benefits, the Bidder agrees that the performance security or portion of the contract amount shall be withheld in favor of the complaining workers pursuant to appropriate provisions of RA No. 12009, without prejudice to the institution of appropriate actions under the Labor Code, as amended, and other social legislations;

- ii) Comply with Occupational Safety and Health Standards (OSHS) and correct deficiencies, if any.

In case of imminent danger, injury or death of the worker, the Bidder undertakes to suspend contract implementation pending clearance to resume from the DOLE Regional Office, in compliance with the Work Stoppage Order; and

- iii) Inform the workers of their conditions of work, labor clauses under the contract specifying wages, hours of work and other benefits under prevailing national laws, rules and regulations; or CBA or arbitration award, if and when applicable, through posting in two (2) conspicuous places in the establishment's premises.

- k) Ensured that it did not give or pay, directly or indirectly, any commission, amount, fee, or any form of consideration, pecuniary or otherwise, to any

person or official, personnel or representative of the government in relation to any procurement project or activity;

- l) Examined all instructions, forms, terms, and specifications in the Bidding Documents;
- m) Determined and complied with all matters pertaining to the contract to be bid, including but not limited to: (i) the location and the nature of the contract, project, or work; (ii) climatic conditions; (iii) transportation facilities; (iv) nature and condition of the terrain, geological conditions at the site communication facilities, requirements, location and availability of construction aggregates and other materials, labor, water, electric power and access roads; and (v) other factors that may affect the cost, duration and execution or implementation of the contract, project, or work; and
- n) Ensured that all information in the Bidding Documents, including bid or supplemental bid bulletin(s) issued, are correct and consistent. The Procuring Entity shall not assume any responsibility regarding erroneous interpretations or conclusions by the prospective or eligible Bidder out of the data furnished by the Procuring Entity.

Failure to observe any of the above responsibilities shall be at the risk of the Bidder concerned;

6.4 The Bidder, by the act of submitting its bid, shall be deemed to have inspected the site, determined the general characteristics of the contract works and the conditions for this Project and examine all instructions, forms, terms, and project requirements in the Bidding Documents.

6.5 Further, the Bidder shall bear all costs associated with the preparation and submission of its bid, and the Procuring Entity shall in no case be responsible or liable for those costs, regardless of the conduct or outcome of the bidding process.

In case of failure of bidding, the Bidding Documents fee may be applied in the re-bidding for the same Project.

6.6 Furthermore, the Bidder should be aware that the Procuring Entity will accept bids only from those that have paid the applicable fee for the Bidding Documents at the office indicated in the Invitation to Bid.

7) **Origin of Goods and Services**

Unless otherwise indicated in the **BDS**, there is no restriction on the origin of Goods, or Contracting of Works or Services other than those prohibited by a decision of the United Nations Security Council taken under Chapter VII of the Charter of the United Nations.

8) **Subcontracts**

8.1 Unless otherwise specified in the **BDS**, the Bidder may subcontract portions of the Works to an extent as may be approved by the HoPE and as stated in the **BDS**. However, the subcontracted portion shall not exceed fifty (50%), or a different percentage of the ABC, on a per project basis, as approved by the GPPB.

8.2 Subcontracting of any portion of the Project shall not relieve the Bidder from any liability or obligation that may arise from the contract.

- 8.3 Subcontractors must meet the eligibility criteria as stated in the **BDS** and shall submit the same eligibility documents as the general contractor. Failure of a subcontractor to meet the eligibility criteria does not affect the eligibility of the general contractor for the procurement project. In such case, the portion intended to be subcontracted to the ineligible subcontractor shall be assumed by the general contractor.
- 8.4 Subcontracting arrangement, if allowed, including the time of submission of the eligibility documents of the subcontractor, shall be disclosed in the **BDS**.

B. Contents of Bidding Documents

9) Pre-Bid Conference

- 9.1 If so specified in the **BDS**, a pre-bid conference shall be held either at the Procuring Entity's physical address and/or online through videoconferencing, webcasting, or similar technology, or a combination thereof, on the date indicated therein, to clarify and address the Bidders' questions on the technical and financial components of this Project.
- 9.2 The pre-bid conference shall be held at least twelve (12) calendar days before the deadline for the submission of and receipt of bids, but not earlier than seven (7) calendar days from the posting of the invitation to bid and other bidding documents on the PhilGEPS website.
- 9.3 Bidders are highly encouraged to attend the pre-bid conference to fully understand the Procuring Entity's requirements. While non-attendance of the Bidder will in no way prejudice its bid, the Bidder is deemed to know any changes and/or amendments to the Bidding Documents, as may be provided in the Supplemental Bid Bulletin.
- The proceedings of the pre-bid conference shall be recorded, and the corresponding minutes shall be prepared not later than five (5) calendar days after the pre-bid conference. The minutes shall be made available to prospective Bidders not later than five (5) days upon written request.
- 9.4 Decisions of the BAC amending any provision of the Bidding Documents shall be issued in writing through a Supplemental Bid Bulletin at least seven (7) calendar days before the deadline for the submission and receipt of bids.

10) Clarification and Amendment of Bidding Documents

- 10.1 Prospective bidders may request for clarification(s) on and/or interpretation of any part of the Bidding Documents. Such a request must be in writing and submitted to the BAC of the Procuring Entity at the address or electronic mail indicated in the **BDS** or through the electronic bidding facility of PhilGEPS, as may be applicable, at least ten (10) calendar days before the deadline set for the submission and receipt of Bids.
- 10.2 The BAC shall respond to the said request by issuing a Supplemental Bid Bulletin duly signed by the BAC Chairperson. It shall be made available to all those who have properly secured the Bidding Documents, at least seven (7) calendar days before the deadline for the submission and receipt of Bids.
- 10.3 Supplemental Bid Bulletins may also be issued upon the Procuring Entity's initiative for purposes of clarifying or modifying any provision of the Bidding Documents not later than seven (7) calendar days before the deadline for the submission and receipt of Bids. Any modification to the Bidding Documents shall be identified as an amendment.

- 10.4 Any Supplemental Bid Bulletin issued by the BAC shall also be posted on the PhilGEPS website, in any conspicuous place in the premises of the Procuring Entity, and on the website or social media platforms of the Procuring Entity, if available, or such other channels as may be authorized by the GPPB. It shall be the responsibility of all prospective bidders, including those who have properly secured the Bidding Documents, to inquire and secure Supplemental Bid Bulletins that may be issued by the BAC. However, Bidders who have submitted bids before the issuance of the Supplemental Bid Bulletin must be accordingly informed by the BAC, and be allowed to modify or withdraw their bids prior to the deadline for the submission and receipt of bids in accordance with ITB Clause 21.

C. Preparation of Bids

11) Language of Bids

The eligibility requirements or statements, the bids, and all other documents to be submitted to the BAC must be in English. If the eligibility requirements or statements, the bids, and all other documents submitted to the BAC are in foreign language other than English, it must be accompanied by a translation of the documents in English. The documents shall be translated by the relevant foreign government agency, the foreign government agency authorized to translate documents, or a registered translator in the foreign bidder's country. The Bidder shall cause the authentication of the translated documents and shall be authenticated by the appropriate Philippine foreign service establishment or post or the equivalent office having jurisdiction over the foreign bidder's affairs in the Philippines. However, for Contracting Parties to the Apostille Convention, the documents shall be authenticated through an apostille by the Competent Authority, as defined in Section 20.2.9.2 of the IRR, except for countries identified by the DFA that will still require legalization (red ribbon) by the relevant Embassy or Consulate. The English translation shall govern, for purposes of interpretation of the bid.

12) Documents Comprising the Bid: Technical and Financial Components

12.1 The first bid envelope shall contain the following technical documents, including the eligibility documents:

- a) PhilGEPS Certificate of Registration (Platinum Membership) in accordance with Section 20 of the IRR;
- b) PCAB License and Registration, in case of Joint Venture (JV);
- c) Statement of all its ongoing government and private contracts, including contracts awarded but not yet started, if any, whether similar or not similar in nature and complexity to the contract to be bid;
- d) Statement of the Bidder's SLCC, in accordance with **ITB** Clause 5.5.

The SLCC shall be supported by an Owner's Certificate of Final Acceptance issued by the project owner other than the Contractor, or a final rating of at least satisfactory in the CPES, or a similar performance and monitoring system. In case of contracts with the private sector, an equivalent document shall be submitted;

- e) NFCC computation in accordance with **ITB** Clause 5.6;
- f) Joint Venture Agreement (JVA), if applicable;

- g) Bid Security in the prescribed form and amount in accordance with **ITB** Clause 16, and validity period under **ITB** Clause 15;
 - h) Project Requirements, which shall include the following:
 - i) Organizational chart of the personnel to be deployed for the procurement project to be bid;
 - ii) List of Contractor's personnel (e.g., Project Manager, Project Engineers, Materials Engineers, and Foremen), to be assigned to the procurement project to be bid, with their complete qualifications and experience data. These personnel must meet the required minimum years of experience set in the **BDS**;
 - iii) List of Contractor's major equipment units which are owned, leased, or under purchase agreements, supported by proof of ownership or certification of availability of equipment from the equipment lessor or vendor for the duration of the project, as the case may be, which must meet the minimum requirements for the contract set in the **BDS**; and
 - iv) Omnibus Sworn Statement in accordance with Section 54.3 of the IRR.
- 12.2 The second bid envelope shall contain the Financial Bid Form, which includes the bid prices and the bill of quantities, in accordance with **ITB** Clauses 13.1.
- 12.3 Whenever necessary, modifications may be made to the foregoing provisions specifically for major and specialized procurement to suit the particular needs of the Procuring Entity, subject to the approval of the GPPB.
- 12.4 All bids that exceed the ABC shall not be accepted. Unless otherwise indicated in the **BDS**, for foreign-funded procurement, the ABC shall be applied as the ceiling to bid prices provided the following conditions are met:
- a) Bidding Documents are obtainable free of charge on a freely accessible website. If payment of Bidding Documents is required by the Procuring Entity, payment could be made upon the submission of bids.
 - b) The Procuring Entity has procedures in place to ensure that the ABC is based on recent estimates made by the engineer or the responsible unit of the Procuring Entity and that the estimates are based on adequate detailed engineering and reflect the quality, supervision and risk, and inflationary factors, as well as prevailing market prices, associated with the types of works or goods to be procured.
 - c) The Procuring Entity has trained cost estimators on estimating prices and analyzing bid variances. In the case of Infrastructure Projects, the Procuring Entity must also have trained quantity surveyors.
 - d) The Procuring Entity has established a system to monitor and report bid prices relative to ABC and engineer's or Procuring Entity's estimate.
 - e) The Procuring Entity has established a monitoring and evaluation system for contract implementation to provide feedback on actual total costs of goods and works.

However, the GoP and the foreign government, or foreign or international financing institutions may agree to waive the foregoing conditions.

13) Bid Prices

- 13.1 The contract shall be for the whole Works, as described in the Bidding Documents, based on the priced Bill of Quantities submitted by the Bidder.
- 13.2 The Bidder shall fill in rates and prices for all items of the Works described in the Bill of Quantities. In case partial bids are allowed in the ITB, bids not addressing or providing all of the required items in the Bidding Documents including, where applicable, the Bill of Quantities, shall be considered non-responsive and shall be automatically disqualified. In this regard, where a required item is provided, but no price is indicated, the same shall be considered as non-responsive, but specifying a zero (0) or a dash (-) for the said item would mean that it is being offered for free to the Government, except those required by law or regulations to be provided for.
- 13.3 For the given scope of work in the contract as awarded, all bid prices shall be considered as fixed prices, and therefore not subject to price escalation during contract implementation, except under extraordinary circumstances as specified in GCC Clause 45.

14) Bid Currencies

- 14.1 All bid prices shall be quoted in Philippine Peso unless otherwise provided in the **BDS**. However, for purposes of bid evaluation, bids denominated in foreign currencies shall be converted to Philippine currency based on the exchange rate as published in the BSP Daily Reference Exchange Rate Bulletin on the day of the bid opening.⁴
- 14.2 If so allowed in accordance with **ITB** Clause 14.1, the Procuring Entity, for purposes of bid evaluation and comparing the bid prices, will convert the currencies in which the bid price is expressed to Philippine Peso at the foreign exchange rates.
- 14.3 Unless otherwise specified in the **BDS**, payment of the contract price shall be made in Philippine Peso.

15) Bid Validity

- 15.1 Bids shall remain valid for the period specified in the **BDS** which shall not exceed one hundred twenty (120) calendar days from the date of the opening of bids.
- 15.2 Should it become necessary to extend the validity of the bids and the bid securities beyond one hundred twenty (120) calendar days, the Procuring Entity concerned shall request in writing all those who submitted bids for such extension before the expiration date therefor. Bidders, however, shall have the right to refuse to grant such extension without forfeiting their Bid Security.

16) Bid Security

⁴ RA No. 8183 or "An Act to Assure Uniform Value to Philippine Coin and Currency."

- 16.1 The Bidder, at its option, shall submit a Bid Security in the form and amount as stated in the **BDS**, which may include the following:

Form of Bid Security	Amount of Bid Security (Not less than the required Percentage of the ABC)
(a) Cash or cashier's/manager's check issued by a bank. <i>For biddings conducted by LGUs, the Cashier's or Manager's check may be issued by other banks certified by the BSP as authorized to issue such financial instrument.</i>	Two percent (2%)
(b) Bank draft/guarantee or irrevocable Letter of Credit issued by a bank; Provided, however, that it shall be confirmed or authenticated by a local bank, if issued by a foreign bank. <i>For biddings conducted by LGUs, the Bank Draft/Guarantee, or irrevocable letter of credit may be issued by other banks certified by the BSP as authorized to issue such financial instrument.</i>	Five percent (5%)
(c) Surety bond callable upon demand issued by a surety or insurance company duly certified by the Insurance on as authorized to issue such security.	Five percent (5%)
(d) Bid Securing Declaration	Not Applicable

The Bid Security shall be denominated in Philippine Peso and posted in favor of the Procuring Entity.

- 16.2 The Bid Security should be valid for the period specified in the **BDS**. Any bid not accompanied by an acceptable Bid Security shall be considered as non-responsive and rejected by the Procuring Entity.
- 16.3 In no case shall the Bid Security be returned later than the expiration of the bid validity period indicated in the Bidding Documents, unless it has been extended in accordance with Section 57.2 of the IRR. In case the bidder is required to extend its bid validity, the bidder may, at its discretion, substitute a Bid Securing Declaration for the extended period as a replacement of its Bid Security; Provided, that the option to substitute is indicated in the **BDS**.
- 16.4 Upon signing and execution of the contract, pursuant to **ITB** Clause 29, and the posting of the performance security pursuant to **ITB** Clause 30, the Bid Security of the successful Bidder's Bid Security will be discharged, but in no case later than its validity period as indicated in **ITB** Clause 15.

16.5 The Bid Security may be forfeited based on any of the following grounds, as provided under Rule VIII, X, XI, and XXI of the IRR:

a) If a Bidder:

- i) With the Lowest Calculated Responsive Bid (LCRB), Most Economically Advantageous Responsive Bid (MEARB), Most Advantageous Responsive Bid (MARB), Single Calculated and Responsive Bid (SCRB), Single Economically Advantageous Responsive Bid (SEARB), or Single Advantageous Responsive Bid (SARB) withdraws, fails, refuses or is unable to: (i) submit the documents required under Section 66.5 of the IRR; (ii) enter into contract with the Procuring Entity; or (iii) post the required performance security within the period stipulated in the IRR and in accordance with **ITB** Clause 30;
- ii) Causes the delay, without justifiable cause, of the screening for eligibility, opening of bids, evaluation and post evaluation of Bids, and awarding of contracts;
- iii) Refuses to clarify or validate in writing its bid during post-qualification within a period of seven (7) calendar days from receipt of the request for clarification;
- iv) Withdraws a bid, or refuses to accept an award, or refuses or fails to enter into contract with the Procuring Entity without justifiable cause, after the approval of the HoPE for having been the declared LCRB or MEARB, as the case may be;
- v) Refuses or fails to furnish performance security within the prescribed time;
- vi) Commits of three (3) or more of any of the acts imposed with suspension, as provided under Section 99 of the IRR;
- vii) Uses force, fraudulent machinations, coercion, undue influence or pressure on any member of the BAC or any officer or employee of the Procuring Entity to take a particular action for its own favor or gain, or to the advantage of a particular bidder;
- viii) Colludes with one (1) or more bidders and submitting different bids as if they were bona fide, when they knew that one or more of them was so much higher than the other that it could not be honestly accepted and that the contract will surely be awarded to the pre-arranged lowest bid;
- ix) Maliciously submits different bids through two (2) or more persons, corporations, partnerships, or any other business entity in which it has interest, to create the appearance of competition that does not in fact exist so as to be declared as the winning bidder;
- x) Enters into an agreement with other bidder/s which call upon one to refrain from bidding for procurement contracts, or which call for withdrawal of bids already submitted, or which are otherwise intended to secure an undue advantage to any of the bidders;

- xi) Fails to faithfully disclose its relationship, regardless of the time of its discovery, with the HoPE, members of the BAC, the TWG, and the BAC Secretariat, the head of the PMO or the End-User or Implementing Unit, and the project consultants of the Procuring Entity, or of the procurement agent, whichever is applicable, by consanguinity or affinity up to the third civil degree pursuant to Section 81 of the IRR;
 - xii) Submits beneficial ownership information containing false entries;
 - xiii) Allows the use of one's name or uses the name of another for purposes of public bidding;
 - xiv) Submits eligibility requirements and bids containing false information or falsified documents or the concealment of such information that will materially alter the outcome of eligibility screening or any stage of the procurement;
 - xv) Accesses the contents of any Bid submitted to the Procuring Entity before the opening of bids, without authorization;
 - xvi) Has any documented attempt to unduly influence the outcome of the bidding;
 - xv) Employs schemes which stifle or suppress any procurement activity; or
 - xvi) Commits a third offense imposed with blacklisting under the Act by the same Procuring Entity, or a combination of three (3) violations imposed with blacklisting by the Procuring Entity and other Procuring Entities, as posted on the GPPB portal;
- b) If a Winning Bidder:
- i) Conducts poor performance or unsatisfactory quality and/or progress of work. Poor performance shall be as follows:
 - i.i) Negative slippage of fifteen percent (15%) and above within the critical path of the project due entirely to the fault or negligence of the winning bidder; or
 - i.ii) Non-compliance of the materials and workmanship with the approved specifications arising from the fault or negligence of the winning bidder.
 - ii) In case it is determined prima facie that the winning bidder has engaged, before or during the implementation of the contract, in the following unlawful deeds and behaviors relative to contract acquisition and implementation:
 - ii.i) Corrupt, fraudulent, collusive and coercive practices;
 - ii.ii) Drawing up or using forged documents; or

- ii.iii) Using adulterated materials, means or methods, or engaging in production contrary to rules of science or trade.
- iii) Assigns or subcontracts the contract or any part thereof or substituting key personnel named in the proposal without prior written approval by the Procuring Entity;
- iv) Willfully or deliberately abandons or does not perform the project or contract by the winning bidder resulting in substantial breach thereof without lawful and/or just cause;
- v) Has its contract terminated due to its default or unlawful acts; or
- vi) Fails to comply with the provision on warranty that requires to repair any noted defect or damage to the Infrastructure Project due to the use of materials of inferior quality within ninety (90) calendar days from the issuance of the order by the HoPE to undertake such repairs.

17) Format and Signing of Bids

- 17.1 Bidders shall submit their bids through their duly authorized representative using the appropriate forms provided in Section IX. Philippine Bidding Documents Related Forms on or before the deadline specified in the **ITB** Clause 19 in two (2) separate sealed bid envelopes which shall be submitted simultaneously, whether through manual or online submission. The first shall contain the technical component of the bid, including the eligibility requirements under **ITB** Clause 12, and the second shall contain the financial component of the bid.
- 17.2 Forms as mentioned in **ITB** Clause 17.1 must be completed without any alterations to their format. No substitute form shall be accepted.
- 17.3 Each and every page of the Bid Form, including the Bill of Quantities, under Section IX hereof, shall be signed by the duly authorized representative/s of the Bidder. Failure to do so shall be a ground for the rejection of the bid.
- 17.4 Any insertions, erasures, or overwriting shall be valid only if they are signed or initialed by the duly authorized representative/s of the Bidder.

18) Sealing and Marking of Bids

- 18.1 Bidders shall enclose their technical documents described in **ITB** Clause 12 in one sealed envelope marked “TECHNICAL COMPONENT,” and the financial component in another sealed envelope marked “FINANCIAL COMPONENT,” sealing them all in an outer envelope marked “BID.”
- 18.2 The Bid shall be typed or written in ink and shall be signed by the Bidder or its duly authorized representative/s.
- 18.3 All envelopes shall:
 - a) contain the name of the contract to be bid in capital letters;
 - b) bear the name and address of the Bidder in capital letters;

- c) be addressed to the Procuring Entity’s BAC in accordance with **ITB** Clause 18.1;
 - d) bear the specific identification of this bidding process indicated in the **ITB** Clause 1.1; and
 - e) bear a warning “DO NOT OPEN BEFORE...” the date and time for the opening of bids, in accordance with **ITB** Clause 19.
- 18.4 For manually submitted bid envelopes that are not properly sealed and marked, as required in the Bidding Documents, the same shall be accepted; Provided, That the bidder or its duly authorized representative shall acknowledge such condition of the bid as submitted. On the other hand, unsealed or unmarked bid envelopes, or bids that cannot be opened or corrupted in case of online submission, shall be rejected.

The BAC shall assume no responsibility for misplaced or lost contents of the improperly sealed or marked bid, or for its premature opening.

D. Submission and Opening of Bids

19) Deadline for Submission of Bids

Bids must be received by the Procuring Entity’s BAC at the address indicated in the **Invitation to Bid**, or through the e-bidding facility of the PhilGEPS, on or before the date and time indicated in the **BDS**.

20) Late Bids

Bids, including the eligibility requirements, submitted after the deadline shall be rejected by the BAC. The BAC shall record in the Minutes of the Meeting the submission and opening of bids, the Bidder’s name, its representative, and the time the late bid was submitted.

21) Modification and Withdrawal of Bids

21.1 Bidders may modify their bids before the deadline for the submission and receipt of bids.

- a) For manual submission and receipt of bids, the Bidders shall not be allowed to retrieve their original bid, but shall only be allowed to submit the bid modification by sending another bid, equally sealed, properly identified, linked to its original bid, and marked as a “modification,” thereof, and stamped “received” by the BAC. Bid modifications received after the applicable deadline shall not be considered and shall be returned to the bidder unopened.
- b) For online submission of bids, the Bidders shall not be allowed to retrieve their original Bid, but shall only be allowed to submit the bid modification, send another Bid equally secured, properly identified labelled as a “modification” of the one previously submitted. The time indicated in the latest bid receipt page generated shall be the official time of submission. Bids modification submitted after the applicable deadline shall not be accepted.

21.2 Bidders may withdraw their bids in writing before the deadline for submission and receipt of bids. Withdrawal of bids after the applicable deadline shall be subject to appropriate sanctions as prescribed in the IRR.

Bidders may also express their intention not to participate in the bidding in writing, which should be received by the BAC before the deadline for submission and receipt of bids. Bidders that withdraw their bids shall no longer be allowed to submit another bid for the same contract, directly or indirectly.

- 21.3 No bid may be modified after the deadline for submission and receipt of bids. Further, no bid may be withdrawn in the interval between the deadline for submission and receipt of bids, and the expiration of bid validity specified by the Bidder in the Financial Bid Form. Withdrawal of bid during this interval shall result in the forfeiture of the Bidder's Bid Security pursuant to **ITB** Clause 16.5, and the imposition of administrative sanctions as prescribed by RA No. 12009 and without prejudice to the imposition of civil and criminal sanctions as provided under applicable laws.

Alternative Bids shall be rejected. For this purpose, Alternative Bid shall pertain to an offer made by a bidder in addition or as a substitute to its original bid, which may be included as part of its original bid or submitted separately. A bid with options shall likewise be considered an Alternative Bid regardless of whether said bid proposal is contained in a single envelope or submitted in two (2) or more separate bid envelopes.

Bidders shall submit offers that comply with the requirements of the Bidding Documents, including the basic technical design as indicated in the drawings and specifications. Unless there is a value engineering clause in the **BDS**, alternative bids shall not be accepted.

Each Bidder shall submit only one Bid, either individually or as a partner in a JV. A Bidder who submits or participates in more than one bid (other than as a subcontractor if a subcontractor is permitted to participate in more than one bid) will cause all the proposals with the Bidder's participation to be disqualified. This shall be without prejudice to any applicable criminal, civil and administrative penalties that may be imposed upon the persons and entities concerned.

22) Opening and Preliminary Examination of Bids

- 22.1 The BAC shall open the bids in public, immediately after the deadline for submission and receipt of bids, as specified in the **BDS**. In case the Bids cannot be opened as scheduled due to justifiable reasons, the BAC shall take custody of the submitted Bids and reschedule the opening of Bids on the next working day or at the soonest possible time, through the issuance of a Notice of Postponement to be posted on the PhilGEPS website and the website of the Procuring Entity concerned.
- 22.2 The manner of opening of the bids for Infrastructure Projects shall depend on the award criterion to be adopted, as follows:
- a) For LCRB and MEARB, the BAC shall open the technical and financial proposals on the same day; and
 - b) For MARB, only the technical proposals shall be opened while the financial proposals shall remain unopened and shall be kept securely by the BAC until the specified time of their opening as indicated in the **BDS**. Only the financial proposals of the bidders who have met the highest technical score for MAB shall be opened.
- 22.3 The Procuring Entity shall prepare the minutes of the proceedings of the bid opening that shall include, as a minimum: (a) names of Bidders, their bid price (per lot, if applicable, and/or including discount, if any), bid security, findings of preliminary

examination, and whether there is a withdrawal or modification; and (b) attendance sheet. The BAC members shall sign the abstract of bids as read.

22.4 The Bidders or their duly authorized representatives may attend the opening of bids. The BAC shall ensure the integrity, security, and confidentiality of all submitted bids. The Abstract of bids, as read, and the minutes of the bid opening shall be made available to the public, upon written request and payment of a specified fee to recover the cost of materials.

22.5 To ensure transparency and accurate representation of the bid submission, the BAC Secretariat shall notify in writing all bidders whose bids it has received through mail at its PhilGEPS-registered physical address or official e-mail address. The said notice shall be issued within seven (7) calendar days from the date of the bid opening.

E. Evaluation and Comparison of Bids

23) Process to be Confidential

23.1 Members of the BAC, its staff and personnel, Secretariat, and TWG, as well as Observers, are prohibited from making or accepting any communication with any bidder regarding the evaluation of their bids until the issuance of the Notice of Award, unless otherwise allowed in the case of **ITB** Clause 24.

23.2 Any effort by a Bidder to influence the Procuring Entity in the Procuring Entity's decision in respect of bid evaluation, bid comparison or contract award will result in the rejection of the bid.

24) Clarification of Bids

To assist in the evaluation, comparison, and post-qualification of the bids, the Procuring Entity may ask in writing any Bidder for a clarification of its bid. All responses to requests for clarification shall be in writing. Any clarification submitted by a Bidder in respect to its bid that is not in response to the request of the Procuring Entity shall not be considered.

25) Detailed Evaluation and Comparison of Bids

25.1 The Procuring Entity's evaluation of bids shall be based on the bid price quoted in the Bid Form, which includes the Bill of Quantities.

25.2 The Procuring Entity will undertake the detailed evaluation and comparison of the bids which have passed the opening and preliminary examination of bids, pursuant to **ITB** Clause 22, to determine the Lowest Calculated Bid (LCB), Most Economically Advantageous Bid (MEAB), and Most Advantageous Bid (MAB).

25.3 The award criterion shall be determined as follows:

a) For LCB:

- i) The detailed evaluation of the financial component of the bids, to establish the correct calculated prices of the bids; and
- ii) The ranking of the total bid prices as so calculated from the lowest to highest, where the bid with the lowest price shall be identified as the LCB.

- b) For MEAB, the BAC shall evaluate the quality and price proposals to determine the MEAB using the following steps:
- i) The quality proposal together with the price proposal shall be considered in the evaluation of bids. The quality proposals shall be evaluated first using the criteria in the **BDS**. The price proposals of the bids that meet the minimum quality score shall then be opened.
 - ii) The price and quality proposals shall be given corresponding weights with the price proposal given a minimum weight of fifteen percent (15%) up to a maximum of forty percent (40%). The weight of the quality criteria shall be adjusted accordingly such that their total weight in percent together with the weight given to the price proposal shall be equal to one hundred percent (100%).
 - iii) To further promote green public procurement, the sustainability of materials or structures with green specifications shall be given greater weight in the evaluation of bids. As approved by the BAC, the exact weights shall be indicated in the **BDS**. The BAC shall rank the bidders in descending order based on the combined numerical ratings of their quality and price proposals. The bidder with the best overall score using the quality-price ratio shall be referred to as the MEAB.
 - iv) The HoPE shall approve or disapprove the recommendations of the BAC within two (2) calendar days after receipt of the results of the evaluation from the BAC.

The quality component shall be assessed on the basis of criteria with corresponding numerical weights indicated in the **BDS**, which may include qualitative, environmental, or social aspects linked to the subject matter of the contract. These may include any or a combination of the following:

- a) Quality and technical merit, including technical competence and a credible track record;
 - b) Aesthetic and functional design and characteristics;
 - c) Approach and methodology;
 - d) Accessibility;
 - e) Tools and equipment;
 - f) Social, environmental, economic, and innovative characteristics;
 - g) Organization, qualification, and experience of employees or staff assigned to perform the contract;
 - h) Ongoing contracts and work commitments; or
 - i) Other relevant criteria in relation to the subject Infrastructure Projects to be procured.
- c) For MAB

- i) The BAC shall evaluate the quality proposals to determine the MAB using the quality components. The quality components shall be assessed on the basis of the criteria with corresponding numerical weights indicated in the **BDS** to determine the bidder with the highest technical rating.
 - ii) The second bid envelope of the bidder obtaining the highest technical rating shall be opened. If the financial proposal is equal to or lower than the ABC, the bid shall be accepted and determined as the MAB; otherwise, the same shall be rejected and the bidder will be disqualified.
- 25.4 In order to eliminate bias in evaluating the quality proposals, it is recommended that the highest and lowest scores for each bidder for each criterion shall not be considered in determining the average scores of the bidders, except when the evaluation is conducted in a collegial manner.
- 25.5 The BAC shall immediately conduct a detailed evaluation of all bids using non-discretionary criteria in considering the following:
- a) Completeness of the bid. Unless the **BDS** allows partial bids, bids not addressing or providing all of the required items in the BDS shall be considered non-responsive and, thus, automatically disqualified.

However, when no price or a zero (0) or a dash (-) is indicated in a required item in the bid form, the same shall be construed that it is being offered for free to the Government, except those required by law or regulations to be provided for; and
 - b) Arithmetical corrections. The BAC shall consider computational errors and omissions to enable proper comparison of all eligible bids. It may also consider bid correction if expressly allowed in the **BDS**. Any adjustment shall be calculated in monetary terms to determine the calculated prices.
- 25.6 Based on the detailed evaluation of bids, those that comply with the above-mentioned requirements shall be ranked in the ascending order of their total calculated bid prices, as evaluated and corrected for computational errors, discounts and other modifications, to identify the LCB, MEAB, or MAB. Total calculated bid prices, as evaluated and corrected for computational errors, discounts and other modifications, which exceed the ABC shall not be considered, unless otherwise indicated in the **BDS**.
- 25.7 The BAC shall evaluate all bids on an equal footing to ensure fair and competitive bid comparison. For this purpose, all bidders shall be required to include in their bids the cost of all taxes, such as, but not limited to, value-added tax (VAT), income tax, local taxes, and other fiscal levies and duties. Such bids, including said taxes, shall be the basis for the bid evaluation and comparison.
- 25.8 If so indicated pursuant to **ITB** Clause 1.1, bids may be submitted for individual lots, or for any combination thereof, provided that all bids and combinations of bids shall be received by the same deadline and opened and evaluated simultaneously so as to determine the bid or combination of bids offering the lowest calculated cost to the Procuring Entity. Bid prices quoted shall correspond to all of the requirements specified for each lot. Bid Security as required by **ITB** Clause 16 shall be submitted for each contract (lot) separately. The basis for evaluation of lots is specified in **BDS** Clause 25.5 (a).

26) Post - Qualification

- 26.1 The BAC shall determine to its satisfaction whether the Bidder that is evaluated as having submitted the LCB, MEAB, or MAB, as the case may be, complies with and is responsive to all the requirements and conditions specified in **ITB** Clauses 5 and 12. The Bidder, within a non-extendible period of five (5) calendar days from receipt of notice from the BAC that it submitted the LCB, MEAB, or MAB, shall submit all the eligibility documents supporting its PhilGEPS Certificate of Registration (Platinum Membership), its latest income and business tax returns filed for the preceding quarter which should not be earlier than two (2) quarters from the date of submission and receipt of bid, and other appropriate licenses and permits required by law and stated in the **BDS**.
- 26.2 Failure to submit any of the post-qualification requirements on time, or a finding against the veracity thereof, shall disqualify the Bidder for award; Provided, That in the event that a finding against the veracity of any of the documents submitted is made, it shall cause the forfeiture of the Bid Security.
- 26.3 The determination shall be based upon an examination of the documentary evidence of the Bidder's qualifications submitted pursuant to **ITB** Clause 12, as well as other information as the Procuring Entity deems necessary and appropriate, using a non-discretionary "pass/fail" criterion, which shall be completed within a period of twelve (12) calendar days.
- 26.4 If the BAC determines that the bidder with the LCB, MEAB, or MAB passes all the criteria for post-qualification, it shall declare the said bid as the LCRB, MEARB, MARB, SCB, SEAB, or Single Advantageous Bid (SAB) and recommend to the HoPE the award of contract to the said bidder at its submitted bid price or its calculated bid price, whichever is lower or, in the case of quality-based evaluation procedure, submitted bid price or its negotiated price, whichever is lower.
- If, however, the BAC determines that the bidder with the LCB, MEAB, MAB, SCB, SEAB, or SAB fails to meet the post-qualification criteria, it shall immediately notify the Bidder in writing of its post-disqualification and the grounds for such determination.⁵
- 26.5 Immediately after the BAC has notified the first bidder of its post-disqualification, and notwithstanding any pending request for reconsideration thereof, the BAC shall initiate and complete the same post-qualification process on the bidder with the second LCB, MEAB, or MAB. If the second bidder passes the post-qualification and provided that the request for reconsideration of the first bidder has been denied, the second bidder shall be post-qualified as the bidder with the LCB, MEAB, or MAB.
- 26.6 If the second bidder, however, fails the post-qualification, the procedure for post-qualification shall be repeated for the bidder with the next LCB, MEAB, or MAB and so on, until the LCRB, MEARB, or MARB, as the case may be, is determined for award, subject to the procedure of Notice and Execution of Award.
- 26.7 Within a period not exceeding ten (10) calendar days from the determination by the BAC of the LCRB, MEARB, MARB, SCRB, SEARB, or SARB and the recommendation to award the contract, the HoPE or its duly authorized representative shall approve or disapprove the said recommendation.

⁵ Sec 63.5 of the IRR.

- 26.8 In case of approval, the HoPE or its duly authorized representative shall immediately issue the Notice of Award to the bidder with the LCRB, MEARB, MARB, SCRB, SEARB, or SARB, as the case may be.

In the event that the approving authority shall disapprove the resolution on the award of the contract, such disapproval shall be based only on valid, reasonable, and justifiable grounds as enumerated under Section 70 of the IRR to be expressed in writing. A copy of the decision disapproving the resolution shall be furnished to the BAC and the bidder.

27) Reservation Clause

- 27.1 Notwithstanding the eligibility or post-qualification of a bidder and without incurring any liability, the HoPE or its duly authorized representative at any stage of the procurement, reserves the right to review its qualifications, reject any and all bids, declare a failure of bidding or not award the contract in the following situations:

- a) If it has reasonable grounds to believe that a misrepresentation has been made by the said bidder; or
- b) If it has reasonable grounds to believe that there has been a change in the bidder's capability to undertake the project from the time it submitted its eligibility requirements.

Should such review uncover any misrepresentation made in the eligibility and bidding requirements, statements or documents, or any changes in the situation of the Bidder which will adversely affect its capability to undertake the Project so that it no longer meets the prescribed eligibility or bid evaluation criteria, the Procuring Entity shall consider the said Bidder as ineligible and disqualify it from participating further in the bidding process or being awarded the contract.

- 27.2 Based on the following grounds, the HoPE or its duly authorized representative reserves the right to reject any and all Bids, declare a Failure of Bidding at any time prior to the contract award, or not to award the contract, without thereby incurring any liability, and make no assurance that a contract shall be entered into as a result of the bidding:

- a) If there is *prima facie* evidence of collusion between appropriate public officers or employees of the Procuring Entity, or between the BAC and any of the bidders, or if the collusion is between or among the bidders themselves, or between a bidder and a third party, including any act which restricts, suppresses or nullifies or tends to restrict, suppress or nullify competition or influences or tends to influence the bidding process;
- b) If the BAC is found to have failed in complying with the applicable law or in following the prescribed bidding procedures; or
- c) If there are any justifiable and reasonable ground where the award of the contract will not redound to the benefit of the government, in instances where (i) the physical and economic conditions have significantly changed so as to render the project no longer economically, financially or technically feasible as determined by the HoPE; (ii) the Project is no longer necessary as determined by the HoPE; and (iii) the source of funds for the Project has been withheld or reduced through no fault of the Procuring Entity.

F. Award of Contract

28) Contract Award

- 28.1 Subject to **ITB** Clause 26, the HoPE or its duly authorized representative shall award the contract to the Bidder whose bid has been determined to be the LCRB, MEARB, MARB, SCRB, SEARB, or SARB, as the case may be.
- 28.2 Prior to the expiration of the period of bid validity, the Procuring Entity shall notify the winning Bidder in writing that its bid has been accepted, through a Notice of Award duly received by the Bidder or its representative personally or by registered mail or electronically, receipt of which must be confirmed in writing within two (2) days by the Bidder with the LCRB, MEARB, MARB, SCRB, SEARB, or SARB, as applicable, and submitted personally or sent by registered mail or electronically to the Procuring Entity.
- 28.3 Within ten (10) calendar days from receipt by the winning bidder of the Notice of Award, the following conditions should be complied with before the contract may be awarded:
- a) Submission of the following documents:
 - i) Valid JVA, if applicable;
 - ii) The SEC Certificate of Registration of the foreign corporation, if applicable; or
 - iii) Valid PCAB license and registration for the type and cost of the Project for foreign bidders when the Treaty or International or Executive Agreement expressly allows submission of such license and registration as a pre-condition to the Notice of Award.
 - b) Posting of the performance security in accordance with **ITB** Clause 30; and
 - c) Signing of the contract as provided in **ITB** Clause 29.

29) Signing of the Contract

- 29.1 Within ten (10) calendar days from receipt of the Notice of Award, the winning Bidder shall post the required performance security, sign and date the contract, and return it to the Procuring Entity.
- 29.2 The Procuring Entity shall enter into a contract with the successful Bidder within the same ten (10) calendar day period provided that all the documentary requirements are complied with.
- 29.3 The following documents shall form part of the contract:

- a) Contract Agreement;
- b) Bidding Documents;
- c) Winning Bidder's bid, including the technical and financial proposals, and all other documents/statements submitted (e.g., Bidder's response to request for clarifications on the bid), including corrections to the bid, if any, resulting from the Procuring Entity's bid evaluation;
- d) Performance Security;
- e) Notice of Award of Contract; and
- f) Other contract documents that may be required by existing laws and/or specified in the **BDS**.

30) Performance Security

- 30.1 To guarantee the faithful performance by the winning bidder of its obligations under the contract, it shall post a performance security prior to the signing of the contract. Furthermore, the successful bidder shall be required to update the performance security posted before to the issuance of a variation order, if any.
- 30.2 Sectors enumerated under Section 76.1⁶ of the IRR may be allowed to post Performance Securing Declaration (PSD) as specified in the **BDS**.
- 30.3 The performance security shall be in a form selected by the Procuring Entity in the amount indicated in the **BDS**, which shall not be less than the percentage of the total contract price in accordance with the following price schedule:

Form of Performance Security	Amount of Performance Security (Not less than the Percentage of the Total Contract Price)
a) Cash or Cashier's or Manager's check issued by a bank. <i>For biddings conducted by LGUs, the cashier's or manager's check may be issued by other banks certified by the BSP</i>	

⁶ Section 76.1. The GPPB, once data is available from relevant agencies, shall maintain a registry of entities belonging to the following sectors:

- a) Farmers as certified by the Department of Agriculture (DA);
- b) Fisherfolk as certified by the Bureau of Fisheries and Aquatic Resources (BFAR);
- c) Persons with disabilities as certified by the National Council for Disability Affairs (NCDA) pursuant to RA No. 7277, otherwise known as the Magna Carta for Disabled Persons, as amended;
- d) Solo parents as certified by the Department of Social Welfare and Development (DSWD); e) Microenterprises and social enterprises as certified by the MSMED Council;
- f) Startups, spin-offs, and other forms of entity involved in science, technology, and innovation activities as certified by the DTI, DICT, NIC or the Department of Science and Technology (DOST), as may be applicable;
- g) Cooperatives duly registered with the CDA pursuant to RA No. 6938, otherwise known as the Cooperative Code of the Philippines, as amended; and
- h) Other relevant sectors as may be determined by the GPPB to ensure inclusivity and diversity in the procurement process.

<i>as authorized to issue such financial instrument.</i>	Ten percent (10%)
b) Bank draft or guarantee or irrevocable Letter of Credit issued by a local bank. If issued by a foreign bank, it shall be confirmed or authenticated by a local bank.	
c) Surety bond callable upon demand issued by a surety or insurance company duly certified by the IC as authorized to issue such security.	Thirty Percent (30%)

30.4 The performance security shall be denominated in Philippine Peso and posted in favor of the Procuring Entity, which shall be forfeited in the event it is established that the winning bidder is in default in any of its obligations under the contract.

31) Notice to Proceed

The Procuring Entity shall issue the Notice to Proceed to the winning Bidder not later than three (3) calendar days from the date of approval of the contract by the appropriate signatories. All notices called for by the terms of the contract shall be effective only at the time of receipt thereof by the successful Bidder.

32) Protest Mechanism

Decisions of the BAC in all stages of procurement may be protested to the HoPE in accordance with Section 83 of the IRR.

Section III. Bid Data Sheet

Bid Data Sheet

ITB Clause	
1.1	<p>The Procuring Entity is Provincial Government of Camarines Norte</p> <p>The Project title is Construction of Water System, Brgy. Hinipaan, Mercedes, Camarines Norte.</p> <p>The identification number of the Contract is ITB-2026-060.</p>
2	<p>The Funding Source is:</p> <p>2.1 The GOP through the source of funding as indicated below for 20% Development Fund AB2026 in the amount of Three Million Nine Hundred Ninety-Five Thousand Nine Hundred Twenty-Four Pesos and Eighty-Seven Centavos (P3,995,924.87).</p> <p>2.2 The source of funding is:</p> <p style="padding-left: 40px;">a. LGUs, the proposed Local Expenditure Program.</p>
3.1	No further instructions.
5.2	Bidding is restricted to eligible bidders as defined in ITB Clause 5.2.
5.4	<p>Contracts similar to the Project shall be those described as follows:</p> <p>Water System Construction</p>

7	No further instructions.																		
8.1	<i>“Subcontracting is not allowed.”</i>																		
8.3	<i>“Not applicable.”</i>																		
9.1	Pre-Bid Conference is on June 18, 2026, 2:00p.m. at <i>2nd Floor, BAC Office, Provincial Capitol Building, Daet, Camarines Norte</i>																		
10.1	<p>The Procuring Entity’s address is:</p> <p><i>2nd Floor, BAC Office</i> <i>Provincial Capitol Bldg., Daet, Camarines Norte</i></p> <p>ENGR. HAROLD R. GESTIADA, EnP <i>P.A.B.E. / Head, BAC Secretariat</i> <i>Baccamnorte2025@gmail.com</i></p>																		
12.1(h)(ii)	<p>The minimum work experience requirements for key personnel are the following:</p> <table border="1"> <thead> <tr> <th><u>Key Personnel</u></th> <th><u>General Experience</u></th> <th><u>Relevant Experience</u></th> </tr> </thead> <tbody> <tr> <td>Project Manager</td> <td>one (1)</td> <td>one (1)</td> </tr> <tr> <td>Project Engineer</td> <td>one (1)</td> <td>one (1)</td> </tr> <tr> <td>Materials Engineer</td> <td>one (1)</td> <td>one (1)</td> </tr> <tr> <td>Safety Officer</td> <td>one (1)</td> <td>one (1)</td> </tr> <tr> <td>Construction Foreman</td> <td>one (1)</td> <td>one (1)</td> </tr> </tbody> </table>	<u>Key Personnel</u>	<u>General Experience</u>	<u>Relevant Experience</u>	Project Manager	one (1)	one (1)	Project Engineer	one (1)	one (1)	Materials Engineer	one (1)	one (1)	Safety Officer	one (1)	one (1)	Construction Foreman	one (1)	one (1)
<u>Key Personnel</u>	<u>General Experience</u>	<u>Relevant Experience</u>																	
Project Manager	one (1)	one (1)																	
Project Engineer	one (1)	one (1)																	
Materials Engineer	one (1)	one (1)																	
Safety Officer	one (1)	one (1)																	
Construction Foreman	one (1)	one (1)																	

12.1(h)(iii)	<p>The minimum major equipment requirements are the following:</p> <table border="1"> <thead> <tr> <th data-bbox="411 443 858 477"><u>Equipment</u></th> <th data-bbox="874 443 1082 477"><u>Capacity</u></th> <th data-bbox="1098 443 1305 477"><u>Number of Units</u></th> </tr> </thead> <tbody> <tr> <td data-bbox="459 510 810 544">1. 4x4 Pickup Type vehicle</td> <td data-bbox="874 510 1082 544"></td> <td data-bbox="1209 510 1225 544">1</td> </tr> <tr> <td data-bbox="459 577 715 611">2. Plate Compactor</td> <td data-bbox="874 577 1082 611"></td> <td data-bbox="1209 577 1225 611">1</td> </tr> <tr> <td data-bbox="459 645 762 678">3. Cargo/Service Truck</td> <td data-bbox="874 645 1082 678"></td> <td data-bbox="1209 645 1225 678">1</td> </tr> <tr> <td data-bbox="459 712 746 745">4. Enough Hand Tools</td> <td data-bbox="874 712 1082 745"></td> <td data-bbox="1209 712 1225 745"></td> </tr> </tbody> </table>	<u>Equipment</u>	<u>Capacity</u>	<u>Number of Units</u>	1. 4x4 Pickup Type vehicle		1	2. Plate Compactor		1	3. Cargo/Service Truck		1	4. Enough Hand Tools		
<u>Equipment</u>	<u>Capacity</u>	<u>Number of Units</u>														
1. 4x4 Pickup Type vehicle		1														
2. Plate Compactor		1														
3. Cargo/Service Truck		1														
4. Enough Hand Tools																
12.4	<p>The ABC is Three Million Nine Hundred Ninety-Five Thousand Nine Hundred Twenty-Four Pesos and Eighty-Seven Centavos (P3,995,924.87). Any bid with a financial component exceeding this amount shall not be accepted.</p>															
14.1	<p>The bid prices shall be quoted in Philippine Peso.</p>															
14.3	<p>Payment shall be made in Philippine Peso.</p>															

15.1	Bids will be valid for <i>120 days</i> from bid opening.
16.1	<p>The Bid Security shall be in the form of a Bid Securing Declaration, and choose at least two (2) from any of the following:</p> <ol style="list-style-type: none"> 1. The amount of not less than 2% of ABC, if bid security is in cash. 2. The amount of not less than 2% of ABC, if bid security is in cashier's check. 3. The amount of not less than 2% of ABC, if bid security is in manager's check. 4. The amount of not less than 5% of ABC, if bid security is in bank draft. 5. The amount of not less than 5% of ABC, if bid security is in guarantee. 6. The amount of not less than 5% of ABC, if irrevocable Letter of Credit. 7. The amount of not less than 5% of ABC, if Surety Bond.
16.2	The Bid Security shall be valid until <i>120 days from opening of bid</i> .
16.3	<p>In case of extension of bid validity and bid security validity period, Substitution of the bid security form is allowed. Bid Securing Declaration and the following forms may be used:</p> <ol style="list-style-type: none"> a) Cash or Cashier's or Manager's Check issued by a Bank. b) Bank draft/guarantee or irrevocable Letter of Credit issued by a Bank: Provided, however, that it shall be confirmed or authenticated by a local Bank, if issued by a foreign bank. c) Surety bond callable upon demand issued by a surety or insurance company duly certified by the Insurance Commission as authorized to issue such security.
19	<p>The address for submission of bids is at 2nd Floor, BAC Office, Provincial Capitol Bldg., Daet, Camarines Norte</p> <p>The deadline for submission of bids is on or before June 30, 2026, at 1:30 p.m.</p>
21.5	"No further instructions."
22.1	<p>The date and time of bid opening is on June 30, 2026, 2:00 p.m. onwards.</p> <p>The place of bid opening is at 2nd Floor, BAC Office, Provincial Capitol Bldg., Daet, Camarines Norte</p>
22.2(b)	"Not applicable".

25.3 (c)(i)	“Not applicable”
25.5 (a)	<p>Partial bid is not allowed. The infrastructure project is packaged in a single lot and the lot shall not be divided into sub-lots for the purpose of bidding, evaluation, and contract award.</p> <p>In all cases, the NFCC computation, if applicable, must be sufficient for all the lots or contracts to be awarded to the Bidder.</p>
25.5 (b)	Bid correction is not allowed.
25.6	No further instructions.
26	<p>For purposes of Post-qualification, the following document(s) shall be required to be submitted/presented within five (5) calendar days from receipt of notice of post-qualification from the BAC:</p> <ol style="list-style-type: none"> 1. Income Tax Returns for year 2021 (BIR Form 1701 or 1702); 2. Latest Value Added Tax Returns (Forms 2550M and 2550Q) or Percentage Tax Returns (Form 2551M) for the last six (6) months before the deadline of the submission of bids. The income tax and business tax returns stated above should have been filed through the Electronic Filing and Payment System (eFPS). 3. Updated Certificate of accomplishments signed by the Owner or Owner's Project Engineer for on-going projects
29.3(f)	<ol style="list-style-type: none"> 1. The documents required in Section 66.5 of the IRR of R.A. 12009 shall form part of the Contract. 2. Additional contract documents relevant to the Project that may be required by existing laws and/or the Procuring Entity, such construction schedule, S-curve, and PERT-CPM, manpower schedule, construction methods, equipment utilization schedule, construction safety and health (CSH) program approved by the DOLE, and other acceptable tools of project scheduling. 3. Preliminary conceptual design plans in accordance with the degree of details specified by the procuring entity; 4. Design and construction methods; and 5. Value engineering analysis of design and construction methods

	6. Program of Work showing the general methods, arrangements, order, and timing for all activities in the work.
30.2	“Not applicable”
30.3	<p>The Performance Security shall be in the form: <i>[choose one from any of the following:]</i></p> <ol style="list-style-type: none"> 1) The amount of not less than 10% of the contract price, if performance security is in cash. 2) The amount of not less than 10% of the contract price, if performance security is in cashier’s check. 3) The amount of not less than 10% of the contract price, if performance security is in manager’s check. 4) The amount of not less than 10% of the contract price, if performance security is in bank draft. 5) The amount of not less than 10% of the contract price, if performance security is in guarantee. 6) The amount of not less than 10% of the contract price, if performance security is irrevocable LoC. Or 7) The amount of not less than 30% of the contract price, if performance security is Surety Bond.

Section IV. General Conditions of Contract

TABLE OF CONTENTS

1. General Terms	52
2. Interpretation.....	52
3. Governing Language and Law	53
4. Communications	53
5. Possession of Site.....	53
6. The Contractor's Obligations	53
7. Subcontracting	54
8. Advance Payment.....	55
9. Progress Payments	56
10. Payment Documents.....	57
11. Retention	57
12. Performance Security	58
13. Detailed Engineering and Site Investigation Reports	59
14. Licenses and Permits.....	60
15. Contractor's Risk and Warranty Security	60
16. Procuring Entity's Risk	62
17. Insurance.....	63
18. Liquidated Damages	64
19. Settlement of Disputes.....	64
20. Liability of the Contractor.....	65
21. Termination for Breach of Contract	65
22. Termination Due to Force Majeure.....	66
23. Termination by Contractor	66
24. Termination for Convenience	67
25. Termination for Unlawful Acts.....	667
26. Termination for Other Causes.....	667
27. Procedures for Termination of Contracts	68
28. Approval of Drawings and Temporary Works by the Procuring Entity	69
29. Acceleration and Delays Ordered by the Procuring Entity	70
30. Contractor's Right to Claim	70
31. Dayworks.....	70
32. Early Warning	70

33. Program of Work.....	70
34. Management Conferences.....	71
35. Bill of Quantities	71
36. Instructions, Inspections and Audits	72
37. Identifying Defects	72
38. Correction of Defects	72
39. Uncorrected Defects	72
40. Variation Orders.....	72
41. Contract Completion	74
42. Suspension of Work	74
43. Payment on Termination	75
44. Extension of Contract Time	75
45. Price Escalation.....	76
46. Completion.....	76
47. Taking Over	77
48. Operating and Maintenance Manuals	77

1) General Terms

In this Contract, the following terms shall be interpreted as indicated:

- 1.1 The **Intended Completion Date** refers to the date specified in the **SCC** when the Contractor is expected to have completed the Works. The intended Completion Date may be revised only by the Procuring Entity by issuing an extension of time or an acceleration order.
- 1.2 The **Procuring Entity** is the party who employs the Contractor to carry out the Works stated in the **SCC**.
- 1.3 The **Site** is the place provided by the Procuring Entity where the Works shall be executed and any other place or places which may be designated in the **SCC**, or notified to the Contractor by the Procuring Entity as forming part of the Site.
- 1.4 The **Start Date**, as specified in the **SCC**, is the date when the Contractor is obliged to commence execution of the Works. It does not necessarily coincide with any of the Site Possession Dates.
- 1.5 **Work(s)** refer to the Permanent Works and Temporary Works to be executed by the Contractor in accordance with this Contract, including (i) the furnishing of all labor, materials, equipment and others incidental, necessary or convenient to the complete execution of the Works; (ii) the passing of any tests before acceptance by the Procuring Entity; (iii) and the carrying out of all duties and obligations of the Contractor imposed by this Contract as described in the **SCC**. In line with this, Temporary Works are works designed, constructed, and installed by the Contractor that are needed for construction or installation of the Permanent Works, which are subsequently removed.

2) Interpretation

- 2.1 In interpreting the Conditions of Contract, singular also means plural, male also means female or neuter, and the other way around. Headings have no significance. Words have their normal meaning under the language of this Contract unless specifically defined. The Procuring Entity will provide instructions clarifying queries about the Conditions of Contract.
- 2.2 If sectional completion is specified in the **SCC**, references in the Conditions of Contract to the Works, the Completion Date, and the Intended Completion Date apply to any Section of the Works (other than references to the Completion Date and Intended Completion Date for the whole of the Works).
- 2.3 The documents forming this Contract shall be interpreted in the following order of priority:
 - a) Contract Agreement;
 - b) Bid Data Sheet;
 - c) Instructions to Bidders;
 - d) Addenda to the Bidding Documents;
 - e) Special Conditions of Contract;

- f) General Conditions of Contract;
- g) Specifications;
- h) Bill of Quantities; and
- i) Drawings.

3) Governing Language and Law

- 3.1 This Contract shall be interpreted in accordance with the laws of the Republic of the Philippines.
- 3.2 This Contract has been executed in the English language, which shall be the binding and controlling language for all matters relating to the meaning or interpretation of this Contract. All correspondence and other documents pertaining to this Contract which are exchanged by the parties shall be written in English.

4) Communications

Communications between parties that are referred to in the Conditions shall be effective only if made in writing. A notice shall be effective only when it is received by the concerned party.

5) Possession of Site

- 5.1 On the date specified in the **SCC**, the Procuring Entity shall grant the Contractor possession of so much of the Site as may be required to enable it to proceed with the execution of the Works. If the Contractor suffers delay or incurs cost from failure on the part of the Procuring Entity to give possession in accordance with the terms of this clause, the Procuring Entity shall give the Contractor a Contract Time Extension and certify such sum as fair to cover the cost incurred, which sum shall be paid by Procuring Entity.
- 5.2 If possession of a portion is not given by the date stated in the **SCC** Clause 1.3, the Procuring Entity will be deemed to have delayed the start of the relevant activities. The resulting adjustments in contract time to address such delay shall be in accordance with **GCC** Clause 44.
- 5.3 The Contractor shall bear all costs and charges for special or temporary right-of-way required by it in connection with access to the Site. The Contractor shall also provide at its own cost any additional facilities outside the Site required by it for purposes of the Works.
- 5.4 The Contractor shall allow the Procuring Entity and any person authorized by the Procuring Entity access to the Site and to any place where work in connection with this Contract is being carried out or is intended to be carried out.

6) The Contractor's Obligations

- 6.1 The Contractor shall carry out the Works properly and in accordance with this Contract. The Contractor shall provide all supervision, labor, Materials, Plant and Contractor's Equipment, which may be required. All Materials and Plant on Site shall be deemed to be the property of the Procuring Entity.

- 6.2 The Contractor shall commence execution of the Works on the Start Date and shall carry out the Works in accordance with the Program of Work submitted by the Contractor, as updated with the approval of the Procuring Entity, and complete them by the Intended Completion Date.
- 6.3 The Contractor shall be responsible for the safety of all activities on the Site.
- 6.4 The Contractor shall carry out all instructions of the Procuring Entity that comply with the applicable laws where the Site is located.
- 6.5 The Contractor shall employ the key personnel named in the Schedule of Key Personnel, as referred to in the **SCC**, to carry out the supervision of the Works. The Procuring Entity will approve any proposed replacement of key personnel only if their relevant qualifications and abilities are equal to or better than those of the personnel listed in the Schedule.
- 6.6 If the Procuring Entity asks the Contractor to remove a member of the Contractor's staff or work force, for justifiable cause, the Contractor shall ensure that the person leaves the Site within seven (7) days and has no further connection with the Work in this Contract.
- 6.7 During Contract implementation, the Contractor and its subcontractors shall abide at all times by all labor laws, including child labor related enactments, and other relevant rules.
- 6.8 The Contractor shall submit to the Procuring Entity for consent the name and particulars of the person authorized to receive instructions on behalf of the Contractor.
- 6.9 The Contractor shall cooperate and share the Site with other contractors, public authorities, utilities, and the Procuring Entity between the dates given in the schedule of other contractors particularly when they shall require access to the Site. The Contractor shall also provide facilities and services for them during this period. The Procuring Entity may modify the schedule of other contractors, and shall notify the Contractor of any such modification thereto.
- 6.10 Should anything of historical or other interest or of significant value be unexpectedly discovered on the Site, it shall be the property of the Procuring Entity. The Contractor shall notify the Procuring Entity of such discoveries and carry out the Procuring Entity's instructions in dealing with them.

7) Subcontracting

- 7.1 Unless otherwise indicated in the **SCC**, the Contractor shall not subcontract portions of the Works beyond the percentage specified in **BDS** Clause 8.1. If subcontracting is allowed, the arrangement, including the timing for submission of the subcontractor's eligibility documents, shall be disclosed.
- 7.2 For subcontracting arrangements, the following rules shall apply for both locally-funded projects and to projects financed through Official Development Assistance, except those covered by treaty, or international, or executive agreements:
 - a) The subcontracted portion of the contract shall be subject to the approval of the HoPE and the following conditions:

- i) The subcontracted portion shall not exceed fifty percent (50%), or a different percentage on a per project basis as approved by the GPPB. The threshold percentages fixed herein shall be subject to the periodic review and adjustments as may be deemed appropriate by the GPPB; and
 - ii) The subcontracted portion shall be limited to components that are not deemed "significant or material" to the project as determined by the Procuring Entity.
- b) Subcontracting arrangement, if allowed, including the time of submission of the eligibility documents of the subcontractor, shall be disclosed in the Bidding Documents;
 - c) Subcontractors must meet the eligibility criteria and shall submit the same eligibility documents as the general contractor.

Failure of a subcontractor to meet the eligibility criteria does not affect the eligibility of the general contractor for the procurement project. In such case, the portion intended to be subcontracted to the ineligible subcontractor shall be assumed by the general contractor;

- d) The general contractor shall remain liable for the subcontractor's actions, defaults, delays, and negligence;
- e) The general contractor and the subcontractor are obliged to comply with the provisions of the contract and shall share liability, jointly and severally, in cases of violation of safety standards or other labor standards insofar as the subcontracted portion is concerned; and
- f) For purposes of post-qualification in accordance with its objective and process under the IRR, the value of the entire completed and accepted Project, including the subcontracted portion, shall be credited as experience of the general contractor. In the case of the subcontractor, the following rules shall apply:
 - i) The subcontractor shall get credit for one hundred percent (100%) of the value of the subcontracted portion of the project performed;
 - ii) Subcontractors shall be eligible to concessional windows of GFIs that treat receivables from the government as loan security; the receivables of subcontractors due from their general contractor shall similarly be accepted as loan security by GFIs; and
 - iii) Contract performance monitoring, such as the use of CPES, among others, shall also be mandatorily applied to the work experience of the subcontractors.

8) Advance Payment

- 8.1 The Procuring Entity shall make an advance payment on the Contract Price to the Contractor in an amount not exceeding fifteen percent (15%) of the total contract price to be made in lump sum or, at the most, two installments according to a schedule specified in the SCC.

- 8.2 The advance payment shall be made only upon:
- i) Written request of the contractor which shall form part of the contract document; and
 - ii) Submission of an irrevocable standby Letter of Credit of equivalent value from a bank as confirmed by the Procuring Entity; a bank guarantee; or a surety bond callable upon demand issued by a duly licensed surety or insurance company, at the option of the Procuring Entity.
- 8.3 The advance payment shall be recovered from the Contractor through deductions in amounts equivalent to the percentage of the total contract price that corresponds to the value of the advance payment granted.
- 8.4 Once a month, Contractors may submit documents, such as Monthly Certificates,⁷ to show the progress or partial completion of a project. The Contractor may reduce its standby letter of credit or guarantee instrument by the amounts refunded by the Monthly Certificates, or any equivalent document subject to auditing and accounting rules, in the advance payment.

9) Progress Payments

- 9.1 Once a month, the Contractor may submit a statement of work accomplished (SWA) or progress billing and corresponding request for progress payment for work accomplished. The SWA should show the amounts which the Contractor considers itself to be entitled to up to the end of the month, to cover (i) the cumulative value of the Works it executed to date, based on the items in the Bill of Quantities, and (ii) adjustments made for approved Variation Orders executed. Alternatively, the Procuring Entity may require in the Bidding Documents that the SWA or progress billing and the corresponding request for progress payment may only be submitted upon actual completion of the Infrastructure Project or a specific portion, segment, milestone or phase thereof.

The Procuring Entity or Project Engineer shall check the Contractor's SWA and certify the amount to be paid to the Contractor as progress payment. Materials and equipment delivered onsite but not yet incorporated in the Works shall not be included for payment, except as otherwise stipulated in the SCC.

- 9.2 The Procuring Entity shall deduct the following from the certified gross amounts to be paid to the Contractor as progress payment:
- a) Cumulative value of the work previously certified and paid for.
 - b) Portion of the advance payment to be recouped.
 - c) Retention money in accordance with the conditions of the contract.
 - d) Amount to cover third-party liabilities.
 - e) Amount to cover uncorrected discovered defects in the Works.

⁷ Commission on Audit (COA) Circular 2012-001.

- 9.3 Payments shall be adjusted by deducting therefrom the amounts for advance payments and retention. The Procuring Entity shall pay the Contractor the amounts certified by the Procuring Entity within twenty-eight (28) days from the date each certificate was issued. No payment of interest for delayed payments and adjustments shall be made by the Procuring Entity.
- 9.4 The first progress payment may be paid by the Procuring Entity to the Contractor, as indicated in the SCC; Provided, That at least a percentage of the Works has been accomplished as certified by the Procuring Entity and as indicated in the SCC.
- 9.5 Items of the Works for which a price of “0” (zero) has been entered will not be paid for by the Procuring Entity and shall be deemed covered by other rates and prices in the Contract.

10) Payment Documents

- 10.1 Subject to existing accounting and auditing rules and regulations,⁸ the Contractor shall submit to the Procuring Entity monthly statements of the estimated value of the work executed less the cumulative amount certified previously.
- 10.2 The Procuring Entity shall check the Contractor’s monthly statement and certify the amount to be paid to the Contractor.
- 10.3 The value of Work executed shall:
- a) be determined by the Procuring Entity;
 - b) comprise the value of the quantities of the items in the Bill of Quantities completed; and
 - c) include the valuations of approved variations.
- 10.4 The Procuring Entity may exclude any item certified in a previous certificate or reduce the proportion of any item previously certified in any certificate in the light of later information.

11) Retention

- 11.1 The Procuring Entity shall retain from each payment due to the Contractor an amount equal to a percentage thereof using the rate as specified in GCC Clause 11.2. The said amount will serve to guarantee indemnity for uncorrected discovered defects and third-party liabilities arising from this Contract. This retention money shall be utilized if the contractor fails to repair the discovered defects. Should the retention money be insufficient, the PE may forfeit the performance security, which may ultimately lead to the termination of the contract.⁹
- 11.2 Progress payments are subject to retention of ten percent (10%) referred to as the retention money. Such retention shall be based on the total amount due to the

⁸ COA Circular No. 2012-001.

⁹ Supreme Court rulings (e.g. *New Bian Yek Commercial, Inc. vs. Office of the Ombudsman, et. al.*, GR No. 169338[2009], and *Tondo Medical Center vs. Rante, G.R. No. 230645 [2019]*) have affirmed this purpose, stating that retention money is a form of security to ensure the satisfactory completion of works and to cover any defects or third-party claims that may arise after project completion.

Contractor prior to any deduction and shall be retained from every progress payment until fifty percent (50%) of the value of the Works, as determined by the Procuring Entity, are completed.

If, after fifty percent (50%) completion, the work is satisfactorily done and on schedule, no additional retention shall be made; otherwise, the ten percent (10%) retention shall be imposed, which may be decreased to 5 percent (5%) by the Procuring Entity based on justifiable causes.¹⁰

- 11.3 The total retention money shall be due for release upon final acceptance of the Works. The Contractor may, however, request the substitution of the retention money for each progress billing with irrevocable standby Letters of Credit from a bank, bank guarantees or surety bonds callable on demand, of amounts equivalent to the retention money substituted for and acceptable to Government; Provided, That the project is on schedule and is satisfactorily undertaken. Otherwise, the ten (10%) percent retention shall be made. Said irrevocable standby letters of credit, bank guarantees and/or surety bonds, to be posted in favor of the Government shall be valid for a duration to be determined by the concerned implementing office/agency or Procuring Entity and will answer for the purpose for which the ten (10%) percent retention is intended, *i.e.*, to cover uncorrected discovered defects and third party liabilities.
- 11.4 On completion of the whole Works, the Contractor may substitute retention money with an “on demand” Bank guarantee in a form acceptable to the Procuring Entity.

12) Performance Security

- 12.1 Within ten (10) calendar days from receipt of the Notice of Award from the Procuring Entity, but in no case later than the signing of the contract by both parties, the winning Contractor shall furnish the performance security in any of the forms prescribed in **ITB** Clause 30 in relation to **BDS** Clause 30.2 and 30.3.
- 12.2 The performance security posted in favor of the Procuring Entity shall be forfeited in the event it is established that the Contractor is in default in any of its obligations under the contract.
- 12.3 The performance security shall remain valid until issuance by the Procuring Entity of the Certificate of Final Acceptance. In case the performance security issued is valid for a specific period shorter than the term of the contract, including the defects liability period, the same shall be renewed or extended as often as necessary and immediately submitted to the Procuring Entity. In case of approved contract time extensions, the Contractor shall cause the extension of the validity of the performance security to cover the said extensions.
- 12.4 The performance security may be released by the Procuring Entity after the issuance of the Certificate of Final Acceptance; Provided, That the Procuring Entity has no claims filed against the performance security.
- 12.5 The Contractor shall post an additional performance security following the amount and form specified in **ITB** Clause 30 to cover any cumulative increase of more than ten

¹⁰ Section 71.2.8 of the IRR.

percent (10%) over the original value of the contract as a result of change orders, extra work orders and supplemental agreements, as the case may be.

- 12.6 In case of a reduction in the contract value or for partially completed Works under the contract which are usable and accepted by the Procuring Entity the use of which, in the judgment of the implementing agency or the Procuring Entity, will not affect the structural integrity of the entire project, the Procuring Entity shall allow a proportional reduction in the original performance security, provided that any such reduction is more than ten percent (10%) and that the aggregate of such reductions is not more than fifty percent (50%) of the original performance security.
- 12.7 Unless otherwise indicated in the **SCC**, the Contractor, by entering into the Contract with the Procuring Entity, acknowledges the right of the Procuring Entity to institute action pursuant to Act No. 3688¹¹ against any subcontractor be they an individual, firm, partnership, corporation, or association supplying the Contractor with labor, materials and/or equipment for the performance of this Contract.

13) Detailed Engineering and Site Investigation Reports

- 13.1 The Contractor, in preparing the Bid, shall rely on all Site Investigation Reports referred to in the **SCC** supplemented by any information obtained by the Contractor.
- 13.2 Detailed engineering shall proceed only on the basis of the feasibility or preliminary engineering study made which establishes the technical viability of the project and conformance to land use and zoning guidelines prescribed by existing laws. The findings contained in the feasibility study, if undertaken for the project, shall be examined. If, in the course of this exercise, it is found that amendments would be desirable in the design standards of principal features, as proposed, specific recommendations for such changes shall be supported by detailed justifications, including their effects on the cost, and the economic justifications, if necessary.
- 13.3 A schedule of detailed engineering activities shall include the following:
- a) Survey;
 - b) Site Investigation;
 - c) Soils and Foundation Investigation;
 - d) Construction Materials Investigation;
 - e) Preparation of Design Plans;
 - f) Preparation of Technical Specifications;
 - g) Preparation of Quantity and Cost Estimates;
 - h) Preparation of Scope of Work;
 - i) Preparation of Proposed Construction Schedule (and estimated Cash Flow for projects with Schedule over six (6) months;

¹¹ Also known as "An Act for the Protection of Persons Furnishing Material and Labor for the Construction Of Public Works".

- j) Preparation of Site or Right-of-Way Plans including Schedule of Acquisition;
 - k) Preparation of Utility Relocation Plan;
 - l) Preparation and Submission of Design Report;
 - m) Environmental Impact Statement for critical project, as defined by the Department of Environment and Natural Resources;
 - n) Preparation of minimum requirements for a Construction Safety and Health Program for the project being considered;
 - o) Value Engineering Studies; and
 - p) Preparation of report on asset climate hazards, risk assessment, disaster response strategies, and readiness planning.
- 13.4 Work under detailed architectural and engineering design shall include, among others, the items stated in Section 8.3 of the IRR.

14) Licenses and Permits

The Procuring Entity may, if requested by the Contractor, assist him in applying for permits, licenses or approvals, which are required for the Works.

15) Contractor's Risk and Warranty Security

- 15.1 From the time project construction commenced up to final acceptance, the Contractor shall assume full responsibility for any damage or destruction of the works, except those occasioned by force majeure; and the safety, protection, security, and convenience of its personnel, third parties, and the public at large, as well as the works, equipment, installation and the like to be affected by its construction work.
- 15.2 The defects liability period for infrastructure projects shall be one (1) year from project completion up to final acceptance by the Procuring Entity. During this period, the Contractor shall undertake the repair works, at its own expense, of any damage to the Works on account of the use of materials of inferior quality, defects in the construction, or due to any violation of the terms of the contract, within ninety (90) calendar days from the time the HoPE has issued an order to undertake repair. In case of failure or refusal to comply with this mandate, the Procuring Entity shall undertake such repair works and shall be entitled to full reimbursement of expenses incurred therein upon demand.
- 15.3 The defects liability period shall be covered by the performance security of the Contractor required in Section 68 of the IRR, which shall guarantee that the Contractor performs its responsibilities stated in **GCC** Clause 15.1 Unless otherwise indicated in the **SCC**, in case the Contractor fails to comply with the preceding paragraph, the Procuring Entity shall forfeit its performance security, subject its properties to attachment or garnishment proceedings, and may impose the appropriate penalty under Sections 99, 100, and 101 of the IRR. All payables of the GoP in its favor shall be offset to recover the costs.
- 15.4 The following persons shall be held responsible for "Structural Defects," i.e., major faults or flaws or deficiencies in one or more key structural elements of the project which may lead to structural failure of the completed elements or structure, or "Structural Failures," i.e., where one or more key structural elements in an

infrastructure facility fails or collapses, thereby rendering the facility or part thereof incapable of withstanding the design loads, and/or endangering the safety of the users or the general public:

- a) Contractor – Where Structural Defects or Failures arise due to faults attributable to improper construction, use of inferior quality/substandard materials, and any violation of the contract plans and specifications, the Contractor shall be held liable;
- b) Consultants – Where Structural Defects or Failures arise due to faulty and/or inadequate design and specifications as well as construction supervision, then the consultant who prepared the design or undertook construction supervision for the project shall be held liable;
- c) Procuring Entity’s Representatives or Project Manager or Construction Managers and Supervisors – The project owner’s representative, project manager, construction manager, and supervisor shall be held liable in cases where the Structural Defects or Failures are due to their willful intervention in altering the designs and other specifications; negligence or omission in not approving or acting on proposed changes to noted defects or deficiencies in the design and/or specifications and the use of substandard construction materials in the project;
- d) Third Parties - Third Parties shall be held liable in cases where Structural Defects or Failures are caused by work undertaken by them such as leaking pipes, diggings or excavations, underground cables and electrical wires, underground tunnel, mining shaft and the like, in which case the applicable warranty to such structure should be levied to third parties for their construction or restoration works; and
- e) Users - In cases where Structural Defects or Failures are due to abuse or misuse by the End-User or Implementing Unit of the constructed facility and/or non-compliance by a user with the technical design limits and/or intended purpose of the same, then the user concerned shall be held liable.

15.5 The warranty against Structural Defects or Failures, except those occasioned by force majeure, shall cover the period specified in the **SCC** reckoned from the date of issuance of the Certificate of Final Acceptance by the Procuring Entity. On the other hand, such warranty shall likewise be applied against non-structural defects for instances that pertain to faults or deficiencies in non-load bearing components or finishes of the Project, such as minor cracks, leaks, or defects in workmanship or materials, which do not affect the stability or safety of the structure but may impact its appearance, functionality, or usability.

15.6 To guarantee that the Contractor shall perform its responsibilities, it shall be required to post a warranty security, which shall be stated in Philippine Peso, in the form chosen by the Procuring Entity in accordance with the following schedule:

Form of Warranty	Amount of Warranty Security Not less than the Percentage (%) of Total Contract Price
(a) Cash or letter of credit issued by bank; Provided, however, that the letter of credit shall be confirmed or authenticated	Five Percent (5%)

<p>by a local bank, if issued by a foreign bank.</p> <p>For biddings conducted by LGUs, the Letter of Credit may be issued by other banks certified by the BSP as authorized to issue such financial instrument.</p>	
<p>(b) Bank guarantee confirmed by bank.</p> <p>For biddings conducted by LGUs, the bank draft/guarantee may be issued by other banks certified by the BSP as authorized to issue such financial instrument.</p>	<p>Ten Percent (10%)</p>
<p>(c) Surety bond callable upon demand issued by GSIS or any surety or insurance company duly certified by the Insurance Commission</p>	<p>Thirty Percent (30%)</p>

- 15.7 The warranty security shall be stated in Philippine Peso and shall remain effective within one (1) year from the date of issuance of the Certificate of Final Acceptance by the Procuring Entity, and returned only after the lapse of the said one (1) year period. This one (1) year period shall cover both structural and non-structural defects or failures; Provided, That in cases of structural defects or failures, warranties beyond the one (1) year period shall be subject to applicable laws, rules, and regulations such as the New Civil Code of the Philippines.
- 15.8 In case of structural/non-structural defects or failure occurring during the applicable warranty period provided in **GCC** Clause 15.5, the Procuring Entity shall undertake the necessary restoration or reconstruction works and shall be entitled to full reimbursement by the parties found to be liable for expenses incurred therein upon demand, without prejudice to the imposition of administrative sanctions as prescribed by RA No. 12009 and without prejudice to the imposition of civil and criminal sanctions as provided under applicable laws against the responsible persons as well as the forfeiture of the warranty security posted in favor of the Procuring Entity.

16) Procuring Entity's Risk

- 16.1 From the Start Date until the Certificate of Final Acceptance has been issued, the following are risks of the Procuring Entity:
- a) The risk of personal injury, death, or loss of or damage to property (excluding the Works, Plant, Materials, and Equipment), which are due to:
 - i) any type of use or occupation of the Site authorized by the Procuring Entity after the official acceptance of the Works; or
 - ii) negligence, breach of statutory duty, or interference with any legal right by the Procuring Entity or by any person employed or contracted by it, except the Contractor.
 - b) The risk of damage to the Works, Plant, Materials, and Equipment to the extent that it is due to a fault of the Procuring Entity or in the Procuring Entity's design, or due to war or radioactive contamination directly affecting the country where the Works are to be executed.

17) Insurance

- 17.1 The Contractor shall, under its name and at its own expense, obtain and maintain, for the duration of this Contract, the following insurance coverage:
- a) Contractor's All Risk Insurance, with an exception for Simple Infrastructure Projects, as applicable;
 - b) Transportation to the project Site of Equipment, Machinery, and Supplies owned by the Contractor;
 - c) Personal injury or death of Contractor's employees; and
 - d) Comprehensive insurance for third party liability to Contractor's direct or indirect act or omission causing damage to third persons.

17.2 The Contractor shall provide evidence to the Procuring Entity that the insurances required under this Contract have been effected and shall, within a reasonable time, provide copies of the insurance policies to the Procuring Entity.

17.3 The Contractor shall notify the insurers of changes in the nature, extent, or program for the execution of the Works and ensure the adequacy of the insurances at all times in accordance with the terms of this Contract and shall produce to the Procuring Entity the insurance policies in force including the receipts for payment of the current premiums.

The above insurance policies shall be obtained from any reputable insurance company approved by the Procuring Entity.

17.4 If the Contractor fails to obtain and keep in force the insurances referred to herein or any other insurance required to be obtained under the terms of this Contract, the Procuring Entity may obtain and keep in force any such insurances and pay such premiums as may be necessary for the purpose. From time to time, the Procuring Entity may deduct the amount it shall pay for said premiums including twenty five percent (25%) therein from any monies due, or which may become due, to the Contractor, without prejudice to the Procuring Entity exercising its right to impose other sanctions against the Contractor pursuant to the provisions of this Contract.

17.5 In the event the Contractor fails to observe the above safeguards, the Procuring Entity may, at the Contractor's expense, take whatever measure is deemed necessary for its protection and that of the Contractor's personnel and third parties, and/or order the interruption of dangerous Works. In addition, the Procuring Entity may refuse to make the payments under GCC Clause 9 until the Contractor complies with this Clause.

17.6 The Contractor shall immediately replace the insurance policy obtained as required in this Contract, without need of the Procuring Entity's demand, with a new policy issued by a new insurance company acceptable to the Procuring Entity for any of the following grounds:

- a) The issuer of the insurance policy to be replaced has:
 - i) become bankrupt;
 - ii) been placed under receivership or under a management committee;

- iii) been sued for suspension of payment;
- iv) been suspended by the Insurance Commission and its license to engage in business or its authority to issue insurance policies has been cancelled; or
- v) Where reasonable grounds exist that the insurer may not be able, fully and promptly, to fulfill its obligation under the insurance policy.

18) Liquidated Damages

- 18.1 When the Contractor fails to satisfactorily complete the Works under the contract within the specified contract duration, inclusive of duly granted time extensions, if any, the Contractor shall be liable for liquidated damages in an amount equal to at least one-tenth (1/10) of one percent (1%) of the cost of the unperformed portion of the Works for every day of delay.
- 18.2 In computing liquidated damages, the Procuring Entity shall determine the usability of the project. A project or a portion thereof may be deemed usable when it starts to provide the desired benefits as certified by the End-User or Implementing Unit and approved by the HoPE.
- 18.3 To be entitled to liquidated damages, the Procuring Entity does not have to prove that it has incurred actual damages. Such amount shall be deducted from any money due, or which may become due the Contractor under the contract, collected from the retention money or other securities posted by the Contractor, or a combination thereof, whichever is convenient to the Procuring Entity.
- 18.4 In case the total sum of liquidated damages reaches ten percent (10%) of the total contract price, the Procuring Entity may rescind or terminate the contract, without prejudice to other courses of action and remedies available under the circumstances.
- 18.5 If the Intended Completion Date is extended after liquidated damages have been paid, the Procuring Entity shall correct any overpayment of liquidated damages by the Contractor by adjusting the next payment schedule.

19) Settlement of Disputes

- 19.1 Any dispute arising from the implementation of a contract covered by the Act and the IRR shall primarily be resolved and settled amicably by mutual consultation or agreement.
- 19.2 In case of failure to settle the dispute amicably, the parties may mutually agree in writing to resort to other modes of alternative dispute resolution (ADR) to promote efficiency in the procurement process. Accordingly, they are encouraged to select the most expeditious mode of ADR available.

If arbitration is chosen as the ADR method, this shall be incorporated as a provision in the contract and referred to the Arbitrator specified in the **SCC**.
- 19.3 If the dispute remains unresolved after exhausting the remedies provided above, it may be submitted to other forms of ADR, such as mediation, conciliation, early neutral evaluation, mini-trial, or any combination thereof, in accordance with RA No. 9285, otherwise known as the "Alternative Dispute Resolution Act of 2004". However,

disputes that are within the competence or jurisdiction of the Construction Industry Arbitration Commission shall be referred to the same for resolution.¹²

20) Liability of the Contractor

Subject to additional provisions, if any, set forth in the **SCC**, the Contractor's liability under this Contract shall be as provided by the laws of the Republic of the Philippines.

21) Termination for Breach of Contract

21.1 The Procuring Entity shall terminate the contract for breach thereof when any of the following conditions are present:

- a) Due to the Contractor's fault and while the project is on-going, it has incurred negative slippage of fifteen percent (15%) or more in accordance with Presidential Decree No. 1870, s. 1983;
- b) Due to the Contractor's fault and after the contract time has expired, it has incurred a negative slippage of ten percent (10%) or more in the completion of the work;
- c) The Contractor abandons the contract works, plainly demonstrates an intention not to continue the performance of the Contractor's obligations under the contract, refuses or fails to comply with the Procuring Entity's instructions, or fails to proceed expeditiously and without delay despite a written notice by the Procuring Entity;
- d) When the Contractor, without reasonable excuse, fails to comply with the Notice of Rejection given by the Project Engineer that, after examination therein, the Infrastructure Project is found to be defective or otherwise not in accordance with the Contract, or a Project Engineer's instruction to conduct remedial work, within 30 days after receiving the said notice;
- e) The Contractor does not actually have on the project site the minimum essential equipment listed on the Bid necessary to prosecute the Works in accordance with the approved work plan and equipment deployment schedule as required for the project;
- f) The Contractor does not execute the Works in accordance with the contract or persistently or flagrantly neglects to carry out its obligations under the contract;
- g) The Contractor neglects or refuses to remove materials or to perform a new work that has been rejected as defective or unsuitable;
- h) The Contractor subcontracts any part of the contract works without approval by the Procuring Entity; or
- i) The Contractor becomes bankrupt or insolvent; goes into liquidation, administration, reorganization, winding-up, or dissolution; becomes subject to the appointment of a liquidator, receiver, administrator, manager, or trustee;

¹² Executive Order No. 1008 (Construction Industry Arbitration Law); and Construction Industry Arbitration Commission Revised Rules of Procedure.

enters into a composition or arrangement with the Contractor's creditors; or any act is done or any event occurs which is analogous to or has a similar effect to any of these acts or events under applicable laws.

- 21.2 All materials on the Site, Plant, Works, including Equipment paid under this Contract, including those identified by the Procuring Entity in the SCC pursuant to GCC Clause 9.1, shall be deemed to be the property of the Procuring Entity if this Contract is terminated because of the Contractor's breach.

22) Termination Due to Force Majeure

- 22.1 For purposes of this Contract the terms "*force majeure*" and "fortuitous event" may be used interchangeably. In this regard, a fortuitous event or *force majeure* shall be interpreted to mean an event which could not have been foreseen, or though foreseen, was inevitable. It shall not include ordinary unfavorable weather conditions, and any other cause the effects of which could have been avoided with the exercise of reasonable diligence by the Contractor.
- 22.2 If this Contract is discontinued by an outbreak of war or by any other similar event entirely outside the control of either the Procuring Entity or the Contractor, the Procuring Entity shall certify that this Contract has been discontinued. The Contractor shall make the Site safe and stop work as quickly as possible after receiving the certificate and shall be paid for all Works carried out before receiving it and for any Work carried out afterwards to which a commitment was made by the Procuring Entity.
- 22.3 If the event continues for a period of eighty-four (84) days, either party may then give notice of termination, which shall take effect twenty-eight (28) days after the giving of the notice.
- 22.4 After termination, the Contractor shall be entitled to payment of the unpaid balance of the value of the Works executed and of the materials and Plant, in relation to GCC Clause 9.1 and 21.2, adjusted by the following:
- (a) any sum to which the Contractor is entitled under GCC Clause 30; and
 - (b) any sum to which the Procuring Entity is entitled.
- 22.5 The net balance due shall be paid or repaid within a reasonable time period from the time of the notice of termination.

23) Termination by Contractor

The Contractor may terminate this Contract with the Procuring Entity if the Works are completely stopped for a continuous period of at least sixty (60) calendar days through no fault of its own, due to any of the following reasons:

- a) Failure of the Procuring Entity to deliver, within a reasonable time, supplies, materials, right-of-way, or other items it is obligated to furnish under the terms of this Contract;
- b) Substantial failure of the Procuring Entity to perform its obligations under the contract, and such failure constitutes a material breach of the Procuring Entity's obligations under the contract;
- c) Prolonged suspension by the Procuring Entity, through no fault of the Contractor, which affects the substantial part of the Infrastructure Project; or

- d) The prosecution of the Work is disrupted by the adverse peace and order situation, as certified by the Armed Forces of the Philippines Provincial Commander and approved by the Secretary of National Defense.

24) Termination for Convenience

The Procuring Entity, by notice sent to the Contractor, may terminate the Contract, in whole or in part, at any time, if it has determined the existence of any of the following conditions that make contract implementation economically, financially, or technically impractical or unnecessary:

- a) If physical and economic conditions have significantly changed so as to render the project no longer economically, financially, or technically feasible, as determined by the HoPE; or
- b) The HoPE has determined the existence of conditions that make project implementation impractical or unnecessary, such as, but not limited to, fortuitous events, changes in laws and government policies.

25) Termination for Unlawful Acts

The Procuring Entity may terminate the contract in case it is determined prima facie that the Contractor, including any joint venture partner therein, has engaged, before or during the implementation of the contract, in unlawful deeds and behaviors relative to contract acquisition and implementation. These unlawful acts include, but are not limited to, the following:

- a) Corrupt, fraudulent, collusive, coercive, and obstructive practices as defined in **ITB** Clause 3.1, unless otherwise specified in the **SCC**;
- b) Drawing up or using forged documents;
- c) Using adulterated materials, means, or methods, or engaging in production contrary to rules of science or trade; or
- d) Any other act analogous to the foregoing.

26) Termination for Other Causes

- 26.1 The Procuring Entity may terminate this Contract, in whole or in part, at any time for its convenience. The HoPE may terminate this Contract for the convenience of the Procuring Entity if physical and economic conditions have significantly changed so as to render the project no longer economically, financially, or technically feasible, as determined by the HoPE; or if the HoPE has determined the existence of conditions that make project implementation impractical or unnecessary, such as, but not limited to, fortuitous events, changes in laws and government policies.
- 26.2 The Procuring Entity or the Contractor may terminate this Contract if the other party causes a fundamental breach of this Contract.
- 26.3 Other breaches of Contract shall include, but shall not be limited to, the following:
 - a) The Contractor stops work for twenty-eight (28) days when no stoppage of work is shown on the current Program of Work and the stoppage has not been authorized by the Procuring Entity;

- b) The Procuring Entity instructs the Contractor to delay the progress of the Works, and the instruction is not withdrawn within twenty-eight (28) days;
 - c) A payment certified by the Procuring Entity is not paid to the Contractor within eighty-four (84) days from the date of the Procuring Entity's certificate;
 - d) The Procuring Entity gives Notice that failure to correct a particular Defect is a fundamental breach of Contract and the Contractor fails to correct it within a reasonable period of time determined by the Procuring Entity;
 - e) The Contractor does not maintain a Security, which is required; and
 - f) The Contractor has delayed the completion of the Works by the number of days for which the maximum amount of liquidated damages can be paid, as defined in the GCC 18.
- 26.4 The Funding Source or the Procuring Entity, as appropriate, will seek the imposition of administrative sanctions as prescribed by RA No. 12009 and without prejudice to the imposition of civil and criminal sanctions as provided under applicable against individuals and organizations deemed to be involved with corrupt, fraudulent, or coercive practices.
- 26.5 When persons from either party to this Contract gives notice of a fundamental breach to the Procuring Entity in order to terminate the existing contract for a cause other than those listed under GCC Clause 26.3, the Procuring Entity shall decide whether the breach is fundamental or not.
- 26.6 If this Contract is terminated, the Contractor shall stop work immediately, make the Site safe and secure, and leave the Site as soon as reasonably possible.

27) Procedures for Termination of Contracts

- 27.1 The following provisions shall govern the procedures for the termination of this Contract:
- a) **Verification** - Upon receipt of a written report of acts or causes which may constitute grounds for termination as aforementioned, or upon its own initiative, the End-User or Implementing Unit shall, within a period of seven (7) calendar days, verify the existence of such grounds and cause the execution of a Verified Report, with all relevant evidence attached;
 - b) **Notice to Terminate** - Upon recommendation by the End-User or Implementing Unit, the HoPE shall terminate contracts only by written notice to the Contractor conveying the termination of the contract. The notice shall state:
 - (i) that the Contract is being terminated for any of the grounds aforementioned, and a statement of the acts that constitute the grounds constituting the same;
 - (ii) the extent of termination, whether in whole or in part;
 - (iii) an instruction to the Contractor to show cause as to why this contract should not be terminated; and

- (iv) special instructions of the Procuring Entity, if any.

The Notice to Terminate shall be accompanied by a copy of the Verified Report;

- c) **Show Cause** - Within a period of seven (7) calendar days from receipt of the Notice of Termination, the Contractor shall submit to the HoPE a verified position paper stating why the contract should not be terminated. If the Contractor fails to show cause after the lapse of the seven (7) day period, either by inaction or by default, the HoPE shall issue an order terminating the contract;
- d) **Rescission of Notice of Termination** - The Procuring Entity may, at any time before receipt of the Contractor's verified position paper, withdraw the Notice to Terminate if it is determined that certain items or works subject of the notice had been completed, delivered, or performed before the Contractor's receipt of the notice;
- e) **Decision** - Within a non-extendible period of ten (10) calendar days from receipt of the verified position paper, the HoPE shall decide whether or not to terminate the contract. It shall serve a written notice to the Contractor of its decision and, unless otherwise provided, the contract is deemed terminated from receipt of the Contractor of the notice of the decision. The termination shall only be based on the grounds stated in the Notice to Terminate.
- f) **Contract Termination Review Committee (CTRC)** - The HoPE may create a committee to assist him in the discharge of its functions under the IRR. All decisions recommended by the CTRC shall be subject to the approval of the HoPE
- g) **Take-over of Contracts** - If a Procuring Entity terminates the contract due to default, insolvency, or for cause, it may enter into a Negotiated Procurement (Take-over of Contracts) pursuant to Section 35.3 of the IRR.
- h) **Notice by Contractor** - The Contractor must serve a written notice to the Procuring Entity of its intention to terminate the contract at least thirty (30) calendar days before its intended termination. The contract is deemed terminated if it is not resumed in thirty (30) calendar days after the receipt of such notice by the Procuring Entity.

27.2 Notwithstanding Section 99 of RA No. 12009 and as provided by applicable laws, the Procuring Entity shall impose on Contractors after the termination of the contract, the penalty of suspension for one (1) year for the first offense, suspension for two (2) years for the second offense from participating in the public bidding process, for violations committed during the contract implementation stage, as stated in the **SCC**.

28) Approval of Drawings and Temporary Works by the Procuring Entity

- 28.1 All Drawings prepared by the Contractor for the execution of the Temporary Works, are subject to prior approval by the Procuring Entity before its use.
- 28.2 The Contractor shall be responsible for design of Temporary Works.
- 28.3 The Procuring Entity's approval shall not alter the Contractor's responsibility for design of the Temporary Works.

- 28.4 The Contractor shall obtain approval of third parties to the design of the Temporary Works, when required by the Procuring Entity.

29) Acceleration and Delays Ordered by the Procuring Entity

- 29.1 When the Procuring Entity wants the Contractor to finish before the Intended Completion Date, the Procuring Entity will obtain priced proposals for achieving the necessary acceleration from the Contractor. If the Procuring Entity accepts these proposals, the Intended Completion Date will be adjusted accordingly and confirmed by both the Procuring Entity and the Contractor.
- 29.2 If the Contractor's Financial Proposals for an acceleration are accepted by the Procuring Entity, they are incorporated in the Contract Price and treated as a Variation.

30) Contractor's Right to Claim

If the Contractor incurs cost as a result of any of the events under GCC Clauses 22, 23 and 24 in relation to GCC Clause 20, the Contractor shall be entitled to the amount of such cost. If as a result of any of the said events, it is necessary to change the Works, this shall be dealt with as a Variation.

31) Dayworks

- 31.1 Subject to GCC Clause 40 on Variation Order, and if applicable as indicated in the SCC, the Contractor shall determine the Dayworks rates to be included or indicated in the Bid. The Dayworks rates in the Contractor's bid shall be used for small additional amounts of work only when the Procuring Entity has given written instructions in advance for additional work to be paid for in that way.
- 31.2 All work to be paid for as Dayworks shall be recorded by the Contractor on forms approved by the Procuring Entity. Each completed form shall be verified and signed by the Procuring Entity within two (2) days of the work being done.
- 31.3 The Contractor shall be paid for Dayworks subject to obtaining signed Dayworks forms from both the Procuring Entity and Contractor.

32) Early Warning

- 32.1 The Contractor shall warn the Procuring Entity at the earliest opportunity of specific likely future events or circumstances that may adversely affect the quality of the work, increase the Contract Price, or delay the execution of the Works.
- 32.2 The Contractor shall cooperate with the Procuring Entity in making and considering proposals for how the effect of such an event or circumstance can be avoided or reduced by anyone involved in the work and in carrying out any resulting instruction of the Procuring Entity. Should such events or circumstances arise which increase the Contract price or delay the execution of Works, the provisions on variation order shall apply.

33) Program of Work

- 33.1 Within the time stated in the SCC, the Contractor shall submit to the Procuring Entity for approval a Program of Work showing the general methods, arrangements, order, and timing for all the activities in the Works.

- 33.2 An update of the Program of Work shall show the actual progress achieved on each activity and the effect of the progress achieved on the timing of the remaining work, including any changes to the sequence of the activities.
- 33.3 The Contractor shall submit to the Procuring Entity for approval an updated Program of Work at intervals no longer than the period stated in the **SCC**. If the Contractor does not submit an updated Program of Work within this period, the Procuring Entity may withhold the amount stated in the **SCC** from the next payment schedule and continue to withhold this amount until the next payment after the date on which the overdue Program of Work has been submitted.
- 33.4 The Procuring Entity's approval of the Program of Work shall not alter the Contractor's obligations. A revised Program of Work produced by the Contractor shall show the effect of any approved Variations, and shall include all Variations. The Contractor may revise the Program of Work, based on the Variation Order, and submit it to the Procuring Entity again.
- 33.5 When the Program of Work is updated, the Contractor shall provide the Procuring Entity with an updated cash flow forecast. The cash flow forecast shall include different currencies, as defined in the Contract, converted as necessary using the Contract exchange rates.

34) Management Conferences

- 34.1 Either the Procuring Entity or the Contractor may require the other to attend a Management Conference. The Management Conference shall review the plans for remaining work and deal with matters raised in accordance with the early warning procedure.
- 34.2 The Procuring Entity shall record the business of Management Conferences and provide copies of the record to those attending the Conference and to the Procuring Entity. The responsibility of the parties for the actions to be taken shall be decided by the Procuring Entity either at the Management Conference or after the Management Conference. The Procuring Entity shall communicate these responsibilities in writing to all who attended the Conference.

35) Bill of Quantities

- 35.1 The Bill of Quantities shall contain items of work for the construction, installation, testing, commissioning of work, materials, and labor among others, to be done by the Contractor.
- 35.2 The Bill of Quantities is used to calculate the Contract Price. The Contractor is paid for the quantity of the work done at the rate in the Bill of Quantities for each item.
- 35.3 If the final quantity of any work item completed differs from the quantity indicated in the Bill of Quantities, and the difference does not exceed twenty-five percent (25%) of the original quantity for that item, the Procuring Entity shall adjust the Contract accordingly.

This shall be allowed only if the total amount of all such changes does not go beyond ten percent (10%) of the total Contract price, subject to applicable laws, rules, and regulations.

- 35.4 If requested by the Procuring Entity, the Contractor shall provide the Procuring Entity with a detailed cost breakdown of any rate in the Bill of Quantities.

36) Instructions, Inspections and Audits

- 36.1 The Procuring Entity shall at all reasonable times during construction of the Works be entitled to examine, inspect, measure and test the materials and workmanship, and to check the progress of the construction.
- 36.2 If the Procuring Entity instructs the Contractor to carry out a test not specified in the Specification to check whether any work has a defect and the test shows that it does, the Contractor shall pay for the test and any samples. In the absence of any defect, the test shall be a compensation event with no adverse consequences to the contractor.
- 36.3 The Contractor shall permit the Funding Source named in the **SCC** to inspect the Contractor's accounts and records relating to the performance of the Contractor and to have them audited by auditors appointed by the Funding Source, if so required by the Funding Source.

37) Identifying Defects

The Procuring Entity shall check the Contractor's work and notify the Contractor of any defects that are found. Such checking shall not affect the Contractor's responsibilities. The Procuring Entity may instruct the Contractor to check noted defects and test any work that the Procuring Entity considers as substandard and/or defective.

38) Correction of Defects

- 38.1 The Procuring Entity shall give notice to the Contractor of any defects before the end of the Defects Liability Period, which is one (1) year from project completion up to final acceptance by the Procuring Entity.
- 38.2 Every time notice of a defect is given, the Contractor shall correct the notified defect within ninety (90) calendar days from the time the HoPE has issued an order to undertake repair.
- 38.3 The Contractor shall correct the defects which they notice themselves before the end of the Defects Liability Period.
- 38.4 The Procuring Entity shall certify that all defects have been duly corrected.

39) Uncorrected Defects

- 39.1 The Procuring Entity shall give the Contractor at least fourteen (14) days' notice of its intention to use a third party to correct a Defect. If the Contractor does not correct the Defect himself within the period, the Procuring Entity may have the Defect corrected by the third party. The cost of the correction will be deducted from the Contract Price.
- 39.2 The use of a third party to correct defects that are uncorrected by the Contractor will in no way relieve the Contractor of its liabilities and warranties under the Contract.

40) Variation Orders

- 40.1 Variation Orders may be issued by the Procuring Entity to cover any increase or decrease in quantities, including the introduction of new work items that are not

included in the original contract or reclassification of work items that are either due to change of plans, design or alignment to suit actual field conditions resulting in disparity between the preconstruction plans used for purposes of bidding and the "as staked plans" or construction drawings prepared after a joint survey by the Contractor and the Government after award of the contract.

Provided, That in case of positive or additive Variation Order/s, the cumulative amount thereof shall not exceed ten percent (10%) of the original contract price; Provided, further, That the scope of works shall not be reduced as to accommodate a positive Variation Order. In all cases, the addition of works under Variation Orders should be within the general scope of the project as bid and awarded.

- 40.2 Any cumulative positive Variation Order beyond ten percent (10%) of the original contract price shall be the subject of another procurement project to be bid out if the Works are separable from the original contract. In exceptional cases where it is urgently necessary to complete the original scope of work, the HoPE, upon the recommendation of the End-User or Implementing Unit, may authorize positive Variation Order/s resulting to a cumulative value of the positive Variation Orders beyond ten percent (10%) but not more than twenty percent (20%) of the original contract price.

All progress payments shall first be charged against the advance payment until the latter has been fully exhausted, at the option of the Procuring Entity.

- 40.3 A Variation Order may either be in the form of a Change Order or Extra Work Order:
- a) A Change Order may be issued by the HoPE or duly authorized representative to cover any increase or decrease in quantities of original work items in the contract.
 - b) An Extra Work Order may be issued by the implementing official to cover the introduction of new work necessary for the completion, improvement or protection of the project which was not included as items of work in the original contract, such as, where there are subsurface or latent physical conditions at the site differing materially from those indicated in the contract, or where there are duly unknown physical conditions at the site of an unusual nature differing materially from those ordinarily encountered and generally recognized as inherent in the work or character provided for in the contract.

- 40.4 For Variation Orders, the Contractor shall be paid for additional work items whose unit prices shall be derived based on the following:
- a) For additional or extra works duly covered by Change Orders involving work items which are exactly the same or similar to those in the original contract, the applicable unit prices of work items original contract shall be used.
 - b) For additional or extra works duly covered by Extra Work Orders involving new work items that are not in the original contract, the unit prices of the new work items shall be based on the direct unit costs used in the original contract (e.g., unit cost of cement, rebars, form lumber, labor rate, equipment rental, etc.). All new components of the new work item shall be fixed prices; Provided, The same is acceptable to both the Government and the Contractor; Provided further, That the direct unit costs of new components shall be based on the Contractor's estimate as validated by the Procuring Entity concerned via documented canvass in accordance with existing rules and regulations. The direct cost of the new work item shall then be combined with the mark-up

factor (i.e., taxes and profit) used by the Contractor in its bid to determine the unit price of the new work item.

40.5 Under no circumstances shall a Contractor proceed to commence work under any Change Order or Extra Work Order unless it has been approved by the HoPE or its duly authorized representative. However, under any of the following conditions, the Procuring Entity's representative or Project Engineer may, subject to the availability of funds and within the limits of its delegated authority, allow the immediate start of work under any Change Order or Extra Work Order:

- a) In the event of an emergency where the prosecution of the work is urgent to avoid detriment to public service, or damage to life and/or property; and/or
- b) When time is of the essence;

Provided, however, That such approval is valid on work done up to the point where the cumulative increase in value of work on the project which has not yet been duly fully approved does not exceed five percent (5%) of the adjusted original contract price.

Provided, further, That immediately after the start of work, the corresponding Change Order or Extra Work Order shall be prepared and submitted for approval in accordance with the abovementioned rules. Payments for Works satisfactorily accomplished on any Change Order or Extra Work Order may be made only after approval of the same by the HoPE or its duly authorized representative.

Provided, finally, That for a Change Order or Extra Work Order involving a cumulative amount exceeding five percent (5%) of the original contract price, no work thereon may be commenced unless said Change Order or Extra Work Order has been approved by the HoPE or its duly authorized representative.

41) Contract Completion

Once the project reaches an accomplishment of ninety-five percent (95%) of the total contract amount, the Procuring Entity may constitute an inspectorate team to conduct preliminary inspection and submit a punch-list to the Contractor in preparation for the final turnover of the project. Said punch-list will contain, among others, the remaining Works, Work deficiencies for necessary corrections, and the specific duration/time to fully complete the project within the approved remaining contract time. This, however, shall not preclude the claim of the Procuring Entity for liquidated damages, if applicable.

42) Suspension of Work

42.1 The Procuring Entity shall have the authority to suspend the work wholly or partly by written order for such period as may be deemed necessary, due to *force majeure* or any fortuitous event or for failure on the part of the Contractor to correct bad conditions which are unsafe for workers or for the general public, to carry out valid orders given by the Procuring Entity or to perform any provisions of the contract, or due to adjustment of plans to suit field conditions as found necessary during construction. The Contractor shall immediately comply with such order to suspend the work wholly or partly.

42.2 The Contractor or its duly authorized representative shall have the right to suspend work operation on any or all projects or activities along the critical path of activities after fifteen (15) calendar days from date of receipt of written notice from the Contractor to the district engineer, regional director, consultant or equivalent official, as the case may be, due to the following:

- a) There exist right-of-way problems which prohibit the Contractor from performing work in accordance with the approved construction schedule.
 - b) Requisite construction plans which must be owner furnished are not issued to the Contractor precluding any work called for by such plans.
 - c) Peace and order conditions that make it extremely dangerous, if not possible, to work. However, this condition must be certified in writing by the Philippine National Police station which has responsibility over the affected area and confirmed by the Department of the Interior and Local Government (DILG) Regional Director.
 - d) There was a failure on the part of the Procuring Entity to deliver government-furnished materials and equipment as stipulated in the contract.
 - e) Delay in the payment of Contractor's claim for progress billing beyond forty-five (45) calendar days from the time the Contractor's claim has been certified by the Procuring Entity's authorized representative that the documents are complete, unless there are justifiable reasons for the delay in payment which shall be communicated in writing to the Contractor.
- 42.3 In case of total suspension, or suspension of activities along the critical path, which is not due to any fault of the Contractor, the elapsed time between the effectivity of the order suspending operation and the order to resume work shall be allowed to the Contractor by adjusting the contract time accordingly.

43) Payment on Termination

- 43.1 If the Contract is terminated because of a breach of Contract by the Contractor, the Procuring Entity shall issue a certificate for the value of the work done and Materials ordered less advance payments received up to the date of the issue of the certificate, and less the percentage to apply to the value of the work not completed, as indicated in the **SCC**. Additional liquidated damages shall not apply. If the total amount due to the Procuring Entity exceeds any payment due to the Contractor, the difference shall be a debt payable to the Procuring Entity.
- 43.2 If the Contract is terminated for the Procuring Entity's convenience, or due to a breach of Contract by the Procuring Entity, the Procuring Entity shall issue a certificate for the value of the work done, Materials ordered, the reasonable cost of removal of Equipment, repatriation of the Contractor's personnel employed solely on the Works, and the Contractor's costs of protecting and securing the Works, and less advance payments received up to the date of the certificate.
- 43.3 The net balance due shall be paid or repaid within twenty-eight (28) days from the notice of termination.
- 43.4 If the Contractor has terminated the Contract under **GCC** Clauses 23 to 24, the Procuring Entity shall promptly return the Performance Security to the Contractor.

44) Extension of Contract Time

- 44.1 Should the amount of additional work or other special circumstances warrant the entitlement of the Contractor to an extension of contract time, the Procuring Entity shall determine the amount of such extension; Provided, That the Contractor has notified the Procuring Entity of its claim for extension of contract time prior to the expiration of

the contract time, and within thirty (30) calendar days after the additional work has been commenced or the circumstances leading to such claim have arisen, as the case may be, in order to give the Procuring Entity the opportunity to investigate the claim. Failure to provide such notice shall constitute a waiver of such a claim by the Contractor. Upon receipt of full and detailed particulars, the Procuring Entity shall examine the facts and extent of the delay and shall extend the contract time to complete the contract work when, in the Procuring Entity's opinion, the findings of facts justify an extension.

- 44.2 No extension of contract time shall be granted to the Contractor due to ordinary unfavorable weather conditions and inexcusable negligence of the Contractor to provide the required equipment, supplies, or materials.
- 44.3 Extension of contract time may be granted only when the affected activities fall within the critical path of the PERT, CPM, Precedence Diagram Method or any other project management tool.
- 44.4 No extension of contract time shall be granted when the reason given to support the request for extension was already considered in the determination of the original contract time during the conduct of detailed engineering and in the preparation of the contract documents as agreed upon by the parties before contract perfection.
- 44.5 Extension of contract time may be granted in the cases indicated in the SCC.
- 44.6 The written consent of the bank, or surety or insurance company, as the case may be, must be attached to any request of the Contractor for extension of contract time and submitted to the Procuring Entity for consideration and the validity of the Performance Security shall be correspondingly extended.
- 44.7 The Procuring Entity shall extend the Intended Completion Date if a Variation is issued which makes it impossible for the Intended Completion Date to be achieved by the Contractor without taking steps to accelerate the remaining work, which would cause the Contractor to incur additional costs. No payment shall be made for any event which may warrant the extension of the Intended Completion Date.
- 44.8 The Procuring Entity shall decide whether and by how much to extend the Intended Completion Date within twenty (20) days of the Contractor asking the Procuring Entity for a decision thereto after fully submitting all supporting information. If the Contractor has failed to give early warning of a delay or has failed to cooperate in dealing with a delay, the delay by this failure shall not be considered in assessing the new Intended Completion Date.

45) Price Escalation

In the event of an extraordinary increase in prices of specific components of the Infrastructure Project, price escalation may be considered, subject to prior approval of the GPPB. If the cost of construction components increases by more than ten percent (10%) of the unit price of work items, as determined against the prevailing price indices of the PSA, a price escalation may be authorized at a no-loss, no-gain basis, using the appropriate formula prescribed by the GPPB. For the purpose of this Section, the PSA shall ensure that its price indices are region-specific and updated on a monthly basis

46) Completion

The Contractor shall request the Procuring Entity to issue a Certificate of Completion of the Works, and the Procuring Entity will do so upon determining that the work is completed.

47) Taking Over

The Procuring Entity shall take over the Site and the Works within seven (7) days from the date of issuance of a Certificate of Completion; Provided, That it shall not release the Contractor of its responsibilities within the defects liability period.

48) Operating and Maintenance Manuals

- 48.1 If “as built” Drawings and/or operating and maintenance manuals are required, the Contractor shall supply them by the dates stated in the SCC.
- 48.2 If the Contractor does not supply the Drawings and/or manuals by the dates stated in the SCC, or they do not receive the Procuring Entity’s approval, the Procuring Entity shall withhold the amount stated in the SCC from payments due to the Contractor.

Section V. Special Conditions of Contract

Special Conditions of Contract

GCC Clause																			
1.1	The Intended Completion Date is 90 Calendar Days reckoned from the start date indicated in the Notice to Proceed (NTP).																		
1.2	The Procuring Entity is <i>Provincial Government of Camarines Norte, Provincial Capitol, Daet, Camarines Norte.</i>																		
1.3	The Site is located at Brgy. Hinipaan, Mercedes, Camarines Norte.																		
1.4	The start date shall be the date of receipt of the Notice to Proceed.																		
1.5	The Works consist of Rehab. of Water Source, Installation of 3150LM Transmission Pipe and Installation of 1 unit tapstand.																		
2.2	Not Applicable.																		
5.1	The PGCN shall give possession of all parts of the Site to the Contractor from the start date indicated in the Notice to Proceed (NTP).																		
6.5	<p>The Contractor shall employ the following Key Personnel:</p> <table border="1" style="width: 100%; border-collapse: collapse;"> <thead> <tr> <th style="text-align: center;"><i>Item No.</i></th> <th style="text-align: center;"><i>Designation</i></th> <th style="text-align: center;"><i>Name</i></th> </tr> </thead> <tbody> <tr> <td style="text-align: center;"><i>1</i></td> <td style="text-align: center;"><i>Project Manager</i></td> <td></td> </tr> <tr> <td style="text-align: center;"><i>2</i></td> <td style="text-align: center;"><i>Project Engineer</i></td> <td></td> </tr> <tr> <td style="text-align: center;"><i>3</i></td> <td style="text-align: center;"><i>Materials Engineer</i></td> <td></td> </tr> <tr> <td style="text-align: center;"><i>4</i></td> <td style="text-align: center;"><i>Safety Officer</i></td> <td></td> </tr> <tr> <td style="text-align: center;"><i>5</i></td> <td style="text-align: center;"><i>Construction Foreman</i></td> <td></td> </tr> </tbody> </table>	<i>Item No.</i>	<i>Designation</i>	<i>Name</i>	<i>1</i>	<i>Project Manager</i>		<i>2</i>	<i>Project Engineer</i>		<i>3</i>	<i>Materials Engineer</i>		<i>4</i>	<i>Safety Officer</i>		<i>5</i>	<i>Construction Foreman</i>	
<i>Item No.</i>	<i>Designation</i>	<i>Name</i>																	
<i>1</i>	<i>Project Manager</i>																		
<i>2</i>	<i>Project Engineer</i>																		
<i>3</i>	<i>Materials Engineer</i>																		
<i>4</i>	<i>Safety Officer</i>																		
<i>5</i>	<i>Construction Foreman</i>																		
7.1	No further instructions.																		
8.1	<p>The advance payment shall be in accordance with Section 71.2.5 of the IRR of R.A. No. 12009.</p> <p>The Procuring Entity shall make an advance payment to the contractor in an amount not exceeding 15% of the total contract price to be made in lump sum or, at the most, two installments according to a schedule specified in the Instruction to Bidders and other relevant bidding document.</p> <p>The advance payment shall be made only upon:</p> <ol style="list-style-type: none"> a. Written request of the contractor which shall form part of the contractor documents; and b. Submission of an irrevocable standby Letter of Credit of equivalent value from a bank as confirmed by the Procuring Entity; a bank guarantee; or a surety bond callable upon demand issued by a duly licensed surety or insurance company, at the option of the Procuring Entity. 																		
9.1	Materials and equipment delivered onsite but not yet incorporated in the Works shall NOT be included for payment.																		

9.4	<p>The advance payment shall be repaid by the contractor by deducting <i>fifteen percent (15%)</i> from his periodic progress payments a percentage equal to the percentage of the total contract price used for the advance payment.</p> <p>The first progress payment may be paid by the Procuring Entity to the Contractor; Provided, that at least <i>five percent (5%)</i> of the Works has been accomplished as certified by the Procuring Entity.</p>
12.7	No further instructions.
13.1	The site investigation reports are: <i>Site survey, boundary stake-out, topographic survey, geotechnical report and all signed and sealed pertinent data related to the conditions of the project site.</i>
15.3	No further instructions.
15.5	<p><i>In case of permanent structures, such as buildings of types 4 and 5 as classified under the National Building Code of the Philippines and other structures made of steel, iron, or concrete which comply with relevant structural codes (e.g., DPWH Standard Specifications), such as, but not limited to, steel/concrete bridges, flyovers, aircraft movement areas, ports, dams, tunnels, filtration and treatment plants, sewerage systems, power plants, transmission and communication towers, railway system, and other similar permanent structures: Fifteen (15) years.</i></p>
20	<p>“No additional provision.” <i>Or if the Contractor is a joint venture, “All partners to the joint venture shall be jointly and severally liable to the Procuring Entity.”</i></p>
25(a)	No further instructions.
27.2	<p>a) Failure of the Contractor, due solely to its fault or negligence, to mobilize and start work or performance within the specified period in the Notice to Proceed (“NTP”);</p> <p>b) Failure by the Contractor to fully and faithfully comply with its contractual obligations without valid cause, or failure by the Contractor to comply with any written lawful instruction of the Procuring Entity or its representative(s) pursuant to the implementation of the contract. For the procurement of infrastructure projects or consultancy contracts, lawful instructions include but are not limited <i>to</i> the following:</p> <ul style="list-style-type: none"> i) Employment of competent technical personnel, competent engineers and/or work supervisors; ii) Provision of warning signs and barricades in accordance with approved plans and specifications and contract provisions; iii) Stockpiling in proper places of all materials and removal from the project site of waste and excess materials, including broken pavement and excavated debris in accordance with approved plans and specifications and contract provisions; iv) Deployment of committed equipment, facilities, support staff and manpower; and v) Renewal of the effectivity dates of the performance security after its expiration during the course of contract implementation.

	<p>c) Assignment and subcontracting of the contract or any part thereof or substitution of key personnel named in the proposal without prior written approval by the Procuring Entity.</p> <p>d) Poor performance by the Contractor or unsatisfactory quality and/or progress of work arising from its fault or negligence as reflected in the CPES rating sheet. In the absence of the CPES rating sheet, the existing performance monitoring system of the Procuring Entity shall be applied. Any of the following acts by the Contractor shall be construed as poor performance:</p> <p>i) Negative slippage of fifteen (15%) and above within the critical path of the project due entirely to the fault or negligence of the Contractor; and</p> <p>ii) Quality of materials and workmanship not complying with the approved specifications arising from the Contractor's fault or negligence.</p> <p>e) Willful or deliberate abandonment or non-performance of the project or contract by the Contractor resulting to substantial breach thereof without lawful and/or just cause.</p> <p>In addition to the penalty of suspension, the performance security posted by the Contractor shall also be forfeited.]</p>
31.1	Dayworks are applicable at the rate shown in the Contractor's original Bid subject to the guidelines on Variation Order in Section 71.2 of the IRR of RA12009.
33.1	The Contractor shall submit the Program of Work to the Procuring Entity within <i>10</i> days of delivery from the Notice of Award.
33.3	The period between Program of Work updates is <i>thirty (30)</i> days. The amount to be withheld for late submission of an updated Program of Work is <i>1% of the contract amount</i> .
36.3	The Funding Source is the PGCN-20% Development Fund AB2026.
43.1	The percentage to apply to the value of the work not completed is <i>10%</i> .

44.5	<p>a) rainy/unworkable days considered unfavorable for the prosecution of the Works at the site, based on the actual conditions obtained at the site, in excess of the number of rainy/unworkable days pre-determined by the Procuring Entity in relation to the original contract time during the conduct of detailed engineering and in the preparation of the contract documents as agreed upon by the parties before contract perfection, and/or</p> <p>b) major calamities such as exceptionally destructive typhoons, floods and earthquakes, and epidemics,</p> <p>c) delays attributable to the Procuring Entity, such as non-delivery on time of materials, working drawings, or written information to be furnished by the Procuring Entity, non-acquisition of permit to enter private properties or non-execution of deed of sale or donation within the right-of-way resulting in complete paralyzation of construction activities, and</p> <p>d) other meritorious causes as determined by the Procuring Entity and approved by the HoPE such as shortage of construction materials, general labor strikes, and peace and order problems that disrupt construction operations through no fault of the Contractor may be considered as additional grounds for extension of contract time provided they are publicly felt and certified by appropriate government agencies such as DTI, DOLE, DILG, and DND, among others.</p>
48.1	<p>The Operating and Maintenance Manuals [one (1) original and three (3) copies and PDF file in flash drive]; and As-Built Drawings [One (1) Original in Mylar, three (3) Blueprint Copies and electronic file in USB] shall be submitted to and approved by the Procuring Entity or its duly authorized representative before the issuance of the Certificate of Completion.</p>
48.2	<p>The amount to be withheld for failing to produce “as built” drawings and/or operating and maintenance manuals by the date required is <i>is final billing and retention money</i>.</p>

Section VI. Specifications

ITEM 1002 – PLUMBING

1002.1 Description

This item shall consist of furnishing all materials, tools, equipment and fixtures required as shown on the Plans for the satisfactory performance of the entire plumbing system including installation in accordance with the edition of the National Plumbing Code, and this Specification.

1002.2 Material Requirements

All piping materials, fixtures and appliances fitting accessories whether specifically mentioned or not but necessary to complete this item shall be furnished and installed.

1002.2.1 Cast Iron Soil Pipes and Fittings

- a. Pipes and fitting materials shall comply with the specification requirements defined in PNS/SAO 4-: 1974. The material and standards of manufacture are herein described:
 1. Cast Iron - the casting shall be made of gray iron which shall be sound, free from cracks, sand and blow holes. They shall be uniformly low hardness that permits drilling and cutting by ordinary methods. Pipes and fittings shall be true to pattern and of compact closed grained structure.
 2. Quality of Iron – the iron shall be made by the cupola, air furnace, electric furnace or other processes which shall be checked by regular chemical and physical control test. The result shall be gray iron of good quality.
 3. Manufacture – the pipes shall be made with hub and spigot ends or hub ends only. All hubs for pipes and fitting shall be provided with held lead grooves and all spigot ends shall be made with beads or plain if machine cast centrifugally. Pugs shall be wrought or cast, machined to the dimension required and shall be free from defects.
 4. Freedom from defects – pipes and fittings shall be true, smooth and cylindrical, their inner and outer surfaces being as nearly concentric as practicable. They shall be in all aspects, sound and good casting free from laps, pin holes or other

imperfections and shall be neatly dressed and carefully fettled. The ends shall be finished reasonably square to their axes.

- b. Clean-outs shall be made of heavy cast brass ferrule with counter sunk screw cover same diameter as the pipe except that they shall not be larger than 100mm diameter.
- c. Caulking lead shall be of molten type peg lead conforming to specification requirements defined in ASTM B-29.
- d. Oakum shall be twisted or braided hemp or abaca fibers slightly impregnated with oil.

1002.2.2 Water Supply Pipes and Fittings

- a. Pipes shall be galvanized iron pipe schedule 40 conforming to specification requirements defined in ASTM A-120 with threaded connection. Under roads where necessary shall be suitably protected as shown on the Plans.

Fittings shall be malleable iron Type II, galvanized iron conforming to specification requirements defined in ASTM A338.

- b. Valves

Valves for water supply shall be bronze body with threaded ends rated 21.0 kg/cm. square. All valves shall be gate valves unless otherwise specified. Gate valves shall have solid wedge body and disc conforming to specification requirements defined in ASTM B-62. Globe valves shall have plug type discs with ferrule threaded ends and bronze body.

- c. Unions

Unions on ferrous pipe 50mm in diameter and smaller shall be malleable iron.

- d. Water Meter

Water meter where required to be furnished by the Contract shall be of the type tested and approved by MWSS.

1002.2.3 Approved Alternate Pipes and Fittings

Pipes and fittings for sanitary and potable water lines as approved alternate shall be Unplasticized Polyvinyl Chloride Pipes and Fittings (UPVC).

Pipes and fittings shall be made of virgin materials conforming to specification requirements define in ASTM D-2241 and PNS 65: 1986. Fitting shall be molded type and designed for solvent cement joint connection for water lines and rubber O-ring seal joint for sanitary lines.

1002.2.4 Septic Tank

The septic tank shall be provided as shown on the Plans including all pipe vents and fittings. The various construction materials such as concrete masonry work shall conform to the corresponding items of this Specification. Inlet and outlet pipes shall conform to the latest edition of the National Plumbing Code.

1002.2.5 Plumbing Fixtures and Fittings

All fittings and trimmings for fixtures shall be chromium-plated and polished brass unless otherwise approved. Exposed traps and supply pipes for fixtures shall be connected to the roughing in, piping system at the wall unless otherwise indicated on the Plans. Built-in fixtures shall be watertight with provision of water supply and drainage outlet, fitting and trap seal. Unless otherwise specified, all plumbing fixtures shall be made of vitreous china complete with fittings.

- a. Water closet shall be vitreous china, free standing toilet combination, round front bottom outlet siphonic washdown bowl with extended rear self and closed coupled tank with cover complete with fittings and mounting accessories. Model make and color shall be submitted for approval prior to delivery at jobsite by the Engineer.
- b. Lavatory shall be vitreous china, wall-hung with rear overflow and cast-in soap dishes, pocket hanger with integral china brackets, complete with twin faucets, supply pipes, P-trap and mounting accessories. Where indicated on the Plans to be counter top model make and color shall be approved by the Engineer.
- c. Urinal shall be china vitreous, wall-hung wash-out urinal with extended shields and integral flush spreader, concealed wall-hanger pockets, 19mm top spud complete with fitting and mounting accessories. Model make and color shall be approved by the Engineer.

1002.2.6 Bathroom and Toilet Accessories

- a. Shower head and fitting shall be movable, cone type with excutcheon arm complete with stainless steel shower valve and control lever, all exposed surface to be chromium finish.
- b. Grab bars shall be made of tubular stainless steel pipe provided with safety grip and mounting flange.
- c. Floor drain shall be made of stainless steel beehive type, measuring 100 x 100mm, and provided with detachable stainless strainer, expanded metal lath type.
- d. Toilet paper holder shall be Vitreous china wall mounted. Color shall reconcile with the adjacent fixture and facing tiles.
- e. Soap holder shall be vitreous china wall mounted. Color shall reconcile with the adjacent tile works.
- f. Faucet(s) shall be made of stainless steel for interior use.
- g. Hose-bib(s) shall be made of bronze cast finish.

1002.2.7 Special Plumbing Fixtures

- a. Kitchen sink shall be made of stainless steel self rimming, single compartment complete with supply fittings strainer traps, dual control lever and other accessories.
- b. Laboratory sink shall be made of cast iron metal with white porcelain finish with single compartment, flat rim ledge, 762mm x 533mm complete with supply fittings, strainer, trap and other accessories.
- c. Scrub-up sink shall be made of cast iron metal with white porcelain finish measuring 610mm x 610mm complete with supply fittings, strainer, trap, and wall mounting accessories.
- d. X-ray developing tank shall be made of cast iron white porcelain finish with three (3) compartment x-ray processing tank, drain plug, open standing drain, 19mm IPS inlet spud complete with stand and mounting accessories.
- e. Squat bowl(s) shall be vitreous china, wash down squat bowl with integral foot treads, pail flush type. Color, make and type to be approved by the Engineer.

- f. Grease traps shall be made of cast bronze with detachable cover and mounting accessories.

1002.2.8 Roof Drain, Downspout, Overflow Pipes and Steel Grating

The Contractors shall provide, fit and/or install necessary drains with strainers, where shown on the Plans. Each drain with strainer shall fit the size of the corresponding downspout (or roof leader) over which it is to be installed and in conformity with the following schedule:

- a. Scupper drains (for balconies, parapet) shall be made of bronze base with flashing. Flange threaded outlet and convex with integral flashing clamp bolted to flange.
- b. "Josam" type drains shall be made of bronze semi-dome with large area, flashing clamp and integral gravel stopper. To be used at roof decks, canopies, gutters, and elsewhere indicated on the Plans.
- c. Downspouts when enhanced in concrete, unless otherwise shown on the Plans shall be polyvinyl chloride (PVC). Whether indicated or specified to be cast iron or galvanizes iron the same shall meet the specification requirement as herein described.
- d. Overflow pipes shall be of galvanized iron pipe measuring at least 13mm diameter and spaced 200mm on center.
- e. Steel grating shall be made of wrought iron metals of design on shop drawings approved and surfaces to be coated with shop finish.

1002.2.9 Fire Protection System

- a. Fire hose cabinets shall be locally available consisting of 38mm diameter valve hose rack with nipple 30mm rubber lined hose cable with standing 4268 kg/cm, square, nozzle 38mm diameter brass, chromium plated.
- b. Fire standingpipe system shall consist of risers and hose valves. Pipes shall be extra black iron. Vales to be high grade cast bronze mounted withstanding 79.40kg. working pressure as indicated on the Plans.
- c. Fire extinguisher shall be portable, suitable for class A, B, C fires, mounted inside cabinet. Cabinet shall be full flush mounting door with aluminum trim

for glass plate, frame and box shall be made of gauge 14 galvanized iron sheet with white interior and red exterior baked enamel finish over primer. Cabinet to be wall mounted and size to be able to accommodate the defined components.

- d. Yard hydrant where shown on the Plans shall match the integrated Fire Department requirements. Outlets shall be single 63mm diameter gate valves with chain connected caps.

1002.2.10 Built-in appliances such as urinal trough, lavatory and slope sink shall be made as indicated on the Plans, exposed surfaces to be tile wainscoting complete with accessories required as practiced in this trade.

1002.3 Construction Requirements

The Contractor before any installation work is started shall carefully examine the Plans and shall investigate actual structural and finishing work condition affecting all his work. Where actual condition necessitates a rearrangement of the approved pipe layout, the Contractor shall prepare Plan(s) of the proposed pipe layout for approval by the Engineer.

1002.3.1 Installation of Soil, Waste, Drain and Vent Pipe

- a. All cast iron soil and drainage pipes shall be pitch 6 mm per 300 mm but in no case flatter than 3mm per 300mm.
- b. Horizontal lines shall be supported by well secured length heavy strap hangers. Vertical lines shall be secured strongly by hooks to the building frame and a suitable brackets or chairs shall be provided at the floor from which they start.
- c. All main vertical soil and waste stacks shall be extended full size to and above the roof line to act as vents, except otherwise indicated on the Plans.

- d. Vent pipes on roof spaces shall be run as close as possible to under side of roof with horizontal piping pitched down to stacks without forming traps. Vertical vent pipes may be connected into one main vent riser above the highest vented fixtures.
- e. Where an end or circuit vent pipe from any fixtures is connected to a vent line serving other fixtures, the connections shall be at least 1.20 m above the floor on which the fixtures are located.
- f. Horizontal waist line receiving the discharge from two or more fixtures shall be provided with end vents unless separate venting of fixtures is noted on the Plans.
- g. All changes on pipe sizes on soil and waste lines shall be made with reducing fittings or recessed reducers. All changes in directions shall be made by appropriate use of 45 degree wyes, half wyes, long sweep quarter bends or elbows may be used in soil and waste lines where the change in the direction of flow is from the horizontal to the vertical and on the discharge from waste closets. Where it becomes necessary to use short radius fittings in other locations the approval of the Engineer shall be obtained prior to installation of the same.
- h. All joints of cast iron pipes in bell and spigot shall be firmly packed with oakum or hemp or caulked with pig at least 25 mm deep.
- i. Cleanouts at the bottom of each soil stack, waste stack, interior down spout and where else indicated shall be the same size as the pipe up to and including 102 mm, 152 mm, for larger pipes.

Cleanouts on floors shall be cast iron ferrule caulked into cast hub and fitted with cast brass screw plug flush with floor. Cleanouts for threaded pipes shall be installed at the foot of soil, waste and drain stacks and on each building drain outside the building.

- j. Vent pipe shall be flashed and made water tight at the roof with ferrule lead sheet. Flushing shall be turned down into pipes.
- k. Each fixtures and place of equipment requiring connection to the drainage system except fixtures with continuous waste shall be equipped with a trap. Each trap shall be placed as near to the fixture as possible. Traps installed on threaded pipe shall be recessed drainage pattern.
- l. Overhead horizontal runs of pipes shall be hung with adjustable wrought iron pipe hanger spaced not over 3.04 m apart except hub and spigot soil pipe which shall have hanger spaced not over 1.50 m apart and located near a hub.

1002.3.7 Inspection, Warranty Test and Disinfection

All pipes, fittings, traps, fixtures, appurtenances and equipment of the plumbing and drainage system shall be inspected and approved by the Engineer to insure compliance with all requirements of all Codes and Regulations referred to in this Specification.

1002.3.7.1 Drainage System Test

- a. The entire drainage and venting system shall have all necessary openings which can be plugged to permit the entire system to be filled with water to the level of the highest stack vent above the roof.
- b. The system shall hold this water for a full 30 minutes during which time there shall be no drop greater than 102 mm.
- c. Where only a portion of the system is to be tested, the test shall be conducted in the same manner as described for the entire system except that a vertical stack 3.00 m highest horizontal line to be tested may be installed and filled with water to maintain sufficient pressure or water pump may be used to supply the required pressure.
- d. If and when the Engineer decides that an additional test is needed, such as an air to smoke test on the drainage system, the Contractor shall perform such test without any additional cost.

1002.3.7.2 Water Test on System

- a. Upon completion of roughing-in and before connecting fixtures the entire cold water piping system shall be tested at a hydrostatic pressure 1 ½ times the expected working pressure in the system during the operation and remained tight and leak-proofed.
- b. Where piping system is to be concealed the piping system shall be separately in manner similar to that described for the entire system and in the presence of the Engineer or his duly designated representative.

1002.3.7.3 Defective Work

- a. All defected materials replaced and tested will be repeated until satisfactory performance is attained.
- b. Any material replaced for the satisfactory performance of the system made shall be at the expense of the Contractor.
- c. Caulking of screwed joints or holes will not be permitted.

1002.3.7.4 Disinfection

- a. The entire water distribution system shall be thoroughly flushed and treated with chlorine before it is operated for public use.
- b. Disinfection materials shall be liquid chlorine or hypochlorite and shall be introduced in a manner approved as practiced or approved by the Engineer into the water distribution system.
- c. After a contact period of not less than sixteen hours, the heavily chlorinated water shall be flushed from the system with potable water.
- d. Valves for the water distribution system shall be opened and closed several times during the 16 hours chlorination treatment is done.

1002.3.8 As-Built Drawings

Upon completion of the work, the Contractor shall submit two sets of prints with all as-built changes shown on the drawings in a neat workmanship manner. Such prints shall show changes or actual installation and conditions of the plumbing system in comparison with the original drawings.

1002.4 Method of Measurement

The work done under this item shall be quantified per length and/or number of units as provided in the Bill of Quantities, tested and accepted to the satisfaction of the Engineer.

1002.5 Basis of Payment

The quantified items, installed in place shall be the basis for payment, based from the unit bid price for which prices and payments shall constitute full compensation including labor, materials and incidentals necessary to complete this item.

Payment shall be made:

Pay Item Number	Description	Unit of Measurement
1002 (a)	Cast Iron Soil pipes and Fittings	pieces/length
1002 (b)	Galvanized Iron Pipes and Fittings	pieces/length
1002 (c)	Plumbing Fixtures	set
1002 (d)	Roof Drain with Strainer	set

ITEM 1201 – WATER PUMPING SYSTEM

1201.1 Description

This item shall consist of furnishing and installation of water pumping system, inclusive of all pipings and pipe fitting connections, valves, controls, electrical wirings, tanks and all accessories ready for service in accordance with the approved Plans and Specifications.

1201.2 Material Requirements

1201.2.1 Water Pump

The type, size, capacity, location, quantity and power characteristics shall be as specified or as shown on the Plans.

1201.2.2 Overhead Tank

The tank shall be provided with manhole, cover, drain pipes, distribution pipe outlet, overflow pipes and air vent.

Suitable float switch or electrode shall be provided in the tank to stop and start the operation of the pump.

1201.2.3 Pneumatic Tank

Tank shall be designed for twice the maximum total dynamic pressure required and shall have the following accessories.

- a) A suitable pressure switch to stop pump if pressure required is attained.
- b) Air volume control device to maintain correct air volume inside the tank.
- c) Pressure relief valve should be installed on top of the tank.
- d) Electrode to be connected in the motor pump control to control the water level.
- e) Air compressor shall be provided for tank of 3,785 liters to maintain air pressure inside the tank.

1201.2.4 Air Compressor

The air compressor shall be electric motor driven with sufficient capacity. The compressor shall be V-belt driven and both motor and compressor shall have V-sheaves on their flywheels. The compressor and motor shall be mounted on a base made of structural steel with anchor clips drilled to permit securing to a foundation.

1201.2.5 Pipes and Fittings

All pipes and fittings shall be G.I. pipe schedule 40.

All pipings 100 mm and larger shall be welded or flanged while smaller sizes shall be screwed.

1201.2.6 Valves

A gate valve followed by a check valve shall be placed between discharge of pump and tank to prevent back flow of water when pump stops.

1201.2.7 Foundation

Refer to sub-section 1200.2.9 – Air Conditioning System

1201.2.8 Electrical Works

Refer to sub-section 1200.2.10 – Air Conditioning System

1201.3 Construction Requirements

Exposed pipings shall be provided with concrete saddle or steel clamps or hangers to secure them firmly to the building structures.

Pipe threads shall be lubricated by white lead, red lead, teflon or other approved lubrication before tightening.

Piping supports shall be placed at 3 m interval or less.

1201.3.1 Test

Appropriate test shall be done to demonstrate that the system complies with the requirements of the Plans and Specifications.

1201.3.1 Guarantee and Service

Refer to sub-section 1200.3.2 – Air Conditioning System.

1201.3.3 Miscellaneous

Refer to sub-section 1200.3.3 – Air conditioning System

1201.4 Method of Measurement

The work under this Item shall be measured either by set, length and piece actually placed and installed as indicated on the Plans. Equipment shall be measured by set, pipes by length, valves and fittings by piece.

1201.5 Basis of Payment

All work performed and measured and as provided for in this Bill of Quantities shall be paid for at the Unit Bid or Contract Unit Price which payment shall constitute full compensation including labor, materials, tools and incidentals necessary to complete this Item.

Payment shall be made under:

Item	Description	Unit of Measurement
(a)	Pump and Water Tank	set
(b)	Air Compressor	set
(c)	Pipe	length
(d)	Valves and Fittings	piece

ITEM 1600 - EXCAVATION

1600.1 Description

This item shall consist of the necessary excavation for removal of all foundation of materials of whatever nature encountered, including all obstructions of any nature that would interfere with the proper execution and completion of the work.

1600.2 Construction Requirements

1600.2.1 General

The removal of said materials shall conform to the lines and grades shown on the approved Plans and Specifications. Unless otherwise provided, the entire construction site shall be stripped of all vegetation and debris and such materials shall be removed from the site prior to performing any excavation. The Contractor shall furnish, place and maintain all supports and shoring that may be required for the sides of the excavation, and all pumping, ditching or other approved measures for the removal or exclusion of water, including taking care of storm water and waste water reaching the site of work from any source so as to prevent damage to the work and adjoining property.

The walls and faces of all excavation in which workers are exposed to danger from unstable ground shall be guarded by means of shoring system, sloping of the excavation, or some other acceptable methods.

The Contractor shall furnish, install and maintain such seething, bracing, etc., as may be necessary to protect the workers and to prevent any movement of earth which could injure or delay the work or endanger adjacent structures. In excavation which workers may be required to enter, excavated or other materials shall be effectively stored and retained at least 600 mm or more from the edge of the excavation and trenching operations shall conform to any and all national, provincial and local safety requirements.

1600.2.2 Excavation Beneath Proposed Structures

Unless otherwise specified for a particular structure or ordered by the Engineer excavation shall be carried to the grade of the bottom of the footing or slab. Where shown or ordered, areas beneath proposed structures shall be over-excavated. After the required excavation or over-excavation has been completed, the exposed surface shall be scarified to the depth of 150 mm brought to optimum moisture content and rolled with heavy compaction equipment to one hundred percent (100%) of maximum density.

1600.2.3 Excavation Beneath Areas to be Paved

Excavation under areas to be paved shall extend to the bottom of the aggregate base, if such base is called for; otherwise it shall extend to the bottom of paving. After the required excavation has been completed, the exposed surface shall be scarified, brought to optimum moisture content, and rolled with heavy compaction equipment to one hundred percent (100%) of maximum density.

1600.2.4 Pipeline Trench Excavation

Unless otherwise shown on the approved Plans, and Specifications or ordered by the Engineer, excavation for pipeline shall be open-cut trenches. The bottom of the trench, including any shoring shall have a minimum width equal to the outside diameter of the pipe plus 300 mm and a maximum width equal to the outside diameter of the pipe plus 600 mm.

except when otherwise shown or ordered by the designated/assigned Engineer, the bottom of the trench shall be excavated uniformly to the grade of the bottom of the pipe. The trench bottom shall be given a final trim using a string line for establishing grade, such that each pipe section when first laid will be wholly in contact with the ground or bedding along the extreme bottom of the pipe. Rounding out the trench to form a cradle shall not be required. The maximum amount of open trench permitted at anyone time and in one location shall be 300 metres or the length necessary to accommodate the number of pipes installed in one day, whichever is greater. Barricades and warning lights satisfactory to the designated/assigned Engineer shall be provided and maintain for all trenches left open overnight except at intersections and driveways in which case heavy steel plates, adequately braced bridges or other type of crossing capable of supporting vehicular traffic shall be furnished as directed by the Engineer.

1600.2.5 Excavation in Lawn Areas

Where pipelines excavation occurs in lawn areas, the sod shall be carefully removed and stockpiled to preserve it for replacement. Excavated material shall be placed on the lawn provided a drop cloth or other suitable method is employed to protect the lawn from

damage. The lawn shall not remain covered for more than 72 hours. Immediately after completion of backfilling and testing of the pipeline, the sod shall be replaced in a manner so as to restore the lawn as near as possible to its original condition.

1600.2.6 Rock Excavation

Rock excavation shall include removal and disposal of the following:

(1) all boulders measuring 0.25 cubic metre or more in volume: (2) All rock material in ledges, bedding deposits and unstratified masses which cannot be removed without systematic drilling and blasting,

1600.2.7 Excavation Beneath Proposed Concrete Reservoir

After the reservoir area has been stripped of all vegetation and debris.

as specified in subsection (1700.2.1), lawn and top soil from the top 600 mm of excavated soil shall be removed and stockpiled for possible later use as fill on or around the reservoir and for miscellaneous top soil.

Excavation under the reservoir shall extend to the bottom of the draindock layer. After such excavation had been completed, the exposed surface shall be rolled with heavy equipment to provide a reasonably smooth surface for placement of draindock.

1600.3 Method of Measurement

The quantity to be paid for shall be the volume of the materials excavated in cubic metre calculated by multiplying the horizontal area of the bottom of the structure or open-cut trench

by the average depth. The average depth shall be calculated from the finished surface of the grade shown on the drawing or the original ground level, whichever is the lowest.

1600.4 Basis of Payment

Payment for all work under this item shall be made at the contract.

unit price per cubic metre for earthwork which price and payment shall be full compensation for furnishing all materials, labor, equipment, tools and incidentals necessary to complete all work.

Payment will be made under:

Pay Item	Description	Unit of
Number		Measurement
1600 (1)	Excavation Beneath Proposed Structures	Cubic metre
(2)	Pipeline Trench Excavation	Cubic metre

ITEM 1601 - BACKFILL AND FILL

1601.1 Description

This item shall consist of all operations required to replace excavated and unsuitable materials to fill up depression to grade or to built up low areas in accordance with the approved Plans and Specifications.

1601.2 Material Requirements

The selected materials shall be free from grass, roots, brush, or other vegetation, or rocks having maximum dimension larger than 150 mm. Materials placed within 150 mm of any structure Or pipe shall be free from rocks or unbroken masses or earthly materials having maximum dimension larger than 75 mm.

1601.3 Construction Requirements

Backfill materials shall be laid in horizontal layers, not more than 200 mm in thickness and compacted to 100 percent of maximum density and to be carried to the level of the surrounding ground or to the lines and grades as shown on the drawings.

Backfill shall not be placed around or upon any structure until the structure has attained sufficient strength to withstand the loads imposed. Special precaution shall be taken to prevent any wedging action against completed structures or facilities. In the course of filling, any sloped surface in the excavation around structure shall be "cut into" horizontally with every layer placed, in order to eliminate any wedge action.

Where the use of power driven compacting equipment would not be practical, layers or materials shall be compacted by any other method which will produce the requirement for compaction.

1601.4 Method of Measurement

The quantity of backfill and fill materials to be paid for under this item shall be the volume which were actually placed and accepted and computed by the average end-area multiplied by total length.

1601.5 Basis of Payment

Payment for all work under this item shall be paid at the contract price per cubic metre for Backfill and Fill, which price and payment shall constitute full compensation for furnishing, hauling, depositing, compacting and leveling, tools and other incidentals necessary to complete the item of work.

Payment will be made under:

Pay Item	Description	Unit of
Number		Measurement
1601	Fill and Backfill	Cubic metre

ITEM 1602 -INSTALLATION OF PIPELINE

1602.1 Description

This item shall consist of furnishing and installation of all pipes, fittings, closure pieces, bolts, nuts, gaskets, jointings materials and appurtenances ;',.

as shown and specified on the drawings, and as required by the designated! assigned Engineer for a complete and workable piping system.

1602.2 Material Requirements

1602.2.1 Mortar Lined and Enamel or Mortar Coated Steel Pipe

1. General - Mortar lined and enamel or mortar coated steel pipe materials and method of manufacture of straight pipe and pipe specials shall conform to Federal Specification SS-P385a dated January 31, 1964 and Amendment-1 dated February 27, 1968 (herein After referred to as "FED SPEC"), subject to the exception and supplemental requirements contained in the following subsections.

The pipe, of the diameter and class shown, shall be furnished complete with rubber gaskets if required and all specials and bends shall be provided as shown. For pipe 350 mm in diameter and larger, the nominal diameter specified or shown shall be the inside diameter after lining. Pipe smaller than 350 mm in diameter may be furnished in standard outside diameters. Plate thickness specified or shown are nominal thickness. Shop drawings of all pipe and specials shall also be furnished.

2. Cement - cement shall conform to ASTM C150 and shall be type 1 for pipe linings and coatings.

3. Aggregate- aggregates shall conform to ASTM C33 to fine aggregates.

4. Cylinder Material - cylinder material shall be fabricated from hot rolled carbon steel sheets or plates conforming to ASTM A570 Grades C,D or E, ASTM A283 Grade D; steel pipe conforming to ASTM A 139 Grade B: or if approved by the designated/assigned Engineer, high strength low-alloy steel conforming to ASTM A572 Grade 42.

5. Rubber Gasket - where rubber gaskets are provided, they shall be continuous ring type, made of special composition rubber. The compound shall be of first grade natural crude, synthetic rubber or a suitable combination thereof. The gasket shall be so formed and cured as to be dense, homogenous, and have a smooth surface free of blisters, pit and other imperfections. The gasket shall be of sufficient volume to fill substantially the recess provided when the joint is assembled and shall be the sole element depended upon to make the joint water-tight. Gaskets shall be furnished with the pipe.

The compound shall conform to the physical requirements listed below:

FED.TEST PHYSICAL REQUIREMENT VALUE METHOD STD.

No.601 Tensile Strength, Min.

Natural Rubber 15.85 MPa 4111

Synthetic Rubber and

Combination 14.47 MPa 4111

Ultimate Elongation, percent min.

Natural 500% 4121

Synthetic & Combination 425% 4121

Shore Durometer, Type A 40-65% 3021

Compression Set, percent of Original Deflection

Max. 20% 3111

Tensile strength after aging percent of original

tensile strength, min.

(oxygen pressure test or 7111*

air heat test) 80% 7221**

* Time 48 hours temperature 70 degrees Centigrade (158 degrees F) 2.0 MPa ** 96 hours at 70 degrees Centigrade (156 degrees F)

6. Welded Joints - where welded joints are provided, weld bell type joints maybe used, or the bell may be cut back, or filler rod added so as to permit field weld between the bell and spigot joint rings.

7. Lining - Except where otherwise specified or shown, lining thickness shall be as follows, with a tolerance of plus or minus twenty-five percent (25%).

Nominal Pipe Lining Thickness (mm)

Diameter (mm)

under 300 6.0

300 to 400 13.0

over 400 19.0

8. Coating - The coating of Steel Pipe shall be of coal tar enamel or cement mortar.

The pipe smaller than 450 mm diameter shall be factory coated with coal tar enamel and bonded asbestos felt wrap as specified in AWWA Standard for Coal Tar Protective Coatings and Linings for Steel Water Pipelines-Enamel and Tape-Hot Applied (AWWA C-203).

Pipe 450 mm diameter and larger, shall be factory coated with coal-tar enamel, fibrous glass mat and bonded asbestos felt wrap as specified in said AWWA Standard.

Coating materials and method of application shall conform to said AWWA Standard except where modified.

Except where otherwise specified or shown, coating thickness shall be 25 mm minimum. Mortar for pipe coating shall consist of one (1) part cement to not more than three (3) parts sand by weight.

9. Curing

The curing periods specified in the Federal Specification are minimum periods. Curing of the Lining shall continue until the exterior coating is applied. The ends of the pipe shall be sealed with heavy plastic sheet during and between placement of the coating and the time the pipe is lowered into the trench. If pipe is steam-cured, recorder charts showing temperature and duration of curing period.

10. Compressive Strength of Mortar

Cylinder shall be molded and tested in accordance with ASTM C39 or C109.

1602.2.2 Cast Iron Water Pipe

Bell and spigot cast iron pipe shall conform to the requirements of the following:

1. "Cast Iron Pipe Centrifugally Cast in Metal Molds for Water or other Liquids" (A WW A

C-1 06) or "Cast Iron Pipe Centrifugally Cast in SandLined Molds for Water or other Liquids" (AWWA C-108), and as indicated in the Bid Schedules or

2. "ISO Recommendation R-13, Cast Iron Pipes, Special Castings and Cast Iron Parts for

Pressure Main Lines." The pipe shall be Class A, however, the hydrostatic test pressure shall be 350 MPa for all sizes.

1602.2.3 Asbestos - Cement Water Pipe

Asbestos-cement water pipe shall conform to the latest edition of the following specifications:

1. International Organization for Standardization (ISO) Recommendation R-160 "Asbestos-Cement Pressure Pipe". Subject to the following additional requirements:

a. Classification Series II, Class 2.45 MPa

b. Internal Hydraulic Pressure Test: A test pressure of 2.45 MPa shall be applied to each length of pipe. The test shall be performed in accordance with ISO 160. clause 2.6.1 except that the application and maintenance of the test pressure may be in accordance with AWWA C-400. Section 5.2.2.1, at the manufacturer's option.

c. Longitudinal Bending Test: A longitudinal bending test shall be performed on each length of the pipe in sizes up to 200 mm diameter when the length exceed 3.0 m. The test shall be performed in accordance with the requirements of AWWA C400 Section 5.2.3 Class 100.

d. Transverse Crushing Test: A transverse crushing test shall be performed as specified in ISO R160. Clause 2,6.3. The number of test shall as specified in ISO clause 4.2.3.

e. Acceptance Test: The consignment shall be delivered with acceptance tests. as specified in ISO R160 Section 4, subject to the additional requirements included herein.

f. Manufacturer's Certificate: The manufacturer shall supply the owner with a certificate showing that the pipe has been tested in accordance with. and satisfies the requirements of the specification as modified herein.

g. Pipe Joints: The tolerance on dimensions of pipe and couplings. as well as the dimensions and specifications of rubber jointing rings, shall be such that an Internal hydraulic pressure of 2.45 MPa can be maintained without leakage when the pipes are set at the maximum angular deviation indicated by the manufacturer of the pipe.

1602.2.4 PVC (Polyvinyl Chloride) Pipe

1. Pipe shall conform to the requirements of "AWWA Standard for Polyvinyl Chloride

(PVC) Pressure Pipe", 100 mm through 300 mm diameter (AWWA C-900) and shall be pressure class 100 or 150 where shown on the drawings and as indicated in the Bid Schedule. The pipe shall have steel pipe equivalent or cast iron equivalent outside dimensions and furnished with rubber ring gasket joints.

Alternate outside diameter and wall thickness shown in the tabulation will be allowed for the specified pressure class.

1602.2.5 Polyethylene (PE) Plastic Pipe

1. Polyethylene pipe shall be manufactured from Type IV, Class C, Grade P34 extrusion

compound as defined by ASTM 01248 with a hydrostatic design stress of 4.3 MPa. Alternate polyethylene pipe extrusion compound PE 3408 according to the Plastic Pipe Institute (PPI) with a hydrostatic design stress of 5.50 MPa may be used. All compound used shall be virgin plastic. Clean rework material from the manufacturer's own pipe production may be used so long as the original was virgin material and of the same type, class and grade as required above. The pipe shall meet the requirements of the National Sanitation Foundation for potable water use as tested by the National Institute of Science and Technology (NIST) or other testing laboratories and shall be made from nontoxic, non-lead based plasticizer approved by the Project Engineer.

2. Pipe dimension when measured to the methods as described in ASTM 02122,

polyethylene pipe shall conform to either of the following dimension depending on the type of extrusion compound used as stipulated above:

Extrusion Compound, Type IV, Class C, Grade P34 (according to ASTM 01248)

Nominal

Size

(mm)

75

100

Outside

Diameter

(mm)

90

110

Wall

Thickness

(min.)

8.18

10.00

Thickness

mm

(max.)

9.30

11.36

150	160	14.55	16.53
-----	-----	-------	-------

200	225	20.45	23.34
-----	-----	-------	-------

3. All polyethelene Pipes shall be rated for use with water at 23 degrees C and at a minirnum working pressure of 1.10 MPa.

4. All PE pipes shall be Ciea'ily markedat inferval 01 notmore than 1.0 lineal metre with

nominal size, type of material, manufacturer's trade name and production code.

1602.3 Construction Requirements

1602.3.1 Mortar Lines and Enamel or Mortar Coated Steel Pipe

1. Unless otherwise provided, the Contractor shall furnish and install all pipes, specials, fittings, closures, pieces, valves, supports, bolts.nuts. gaskets; jointing materials and all other appurtenances as shown and as required to provide a complete and workable installation. Where pipe support details are shown. the support shall conform thereto and shall be placed as Indicated; provided, that the support for all exposed piping shall be complete and adequate regardless of whether or not supporting devices are specifically shown. Concrete thrust blocks. anchor blocks or welded joints shall be provided at all junctions, changes in direction exceeding 11-1/2 degrees or where otherwise shown. At all times when the work of installing pipe is not in progress, all openings into the pipe and

at the ends of the pipe in trenches or structures shall be kept tightly closed to prevent entrance of animals and foreign materials. The Contractor shall take all necessary precautions to prevent the pipe from floating due to water entering the trench from any source, shall assume full responsibility for any damages due to this cause and shall at his own expense restore and replace the pipe to its specified condition and grade if it is displaced due to floating. The Contractor shall maintain the inside of the pipe free from foreign materials and in a clean and sanitary condition until its acceptance by the Owner.

2. Trenches shall be in a reasonably dry condition when the pipe is laid. Necessary facilities

including slings shall be provided for lowering and properly placing the pipe section in the trench without damage. The pipe sections shall be laid to the line and grade when shown and they shall be closely jointed to form a smooth flow line. Immediately before placing each section of pipe in final position for joining, the bedding for the pipe shall be checked for firmness and uniformity of surface.

1602.3.2 Cast Iron Water Pipe

Cast iron and fitting shall be lined with cement mortar in accordance with the requirement of the "Standard for Installation of Cast Iron Water Mains" (AWWA C-600).

1602.3.3 Asbestos - Cement Water Pipe

Asbestos-cement pipe shall be installed in accordance with the "Standard for Installation of Asbestos-Cement Water Pipe" (AWWA C603), except that the pipe shall not be laid using earth mounds.

Prior to installation, the asbestos-cement pipe and couplings and all rubber rings shall be inspected for damages and defects in materials and workmanship. All damaged or defective materials shall be rejected and removed from the jobsite.

Joints between asbestos-cement pipe to cast-iron valves and fittings shall be sealed with rubber ring gaskets. After assembling the joint, the position of the rubber ring gaskets shall be located at even distance from the face of the valve or fitting, for the full circumference of the pipe.

1602.3.4 PVC (Polyvinyl Chloride) Pipe

After a section of a pipe has been lowered into the prepared trench and immediately before joining the pipe, the ends of the pipe to be joined shall be cleaned, and the rubber gasket

lubricated, with a vegetable compound soap all in accordance with the pipe manufacturer's instructions. Assembly of the pipe length shall be in accordance with the recommendation of the manufacturer of the type of the joint use, All special tools and appliances required for joining the pipe shall be provided by the Contractor. When cutting or machining of the pipe is necessary, only tools and methods recommended by the pipe manufacturer and approved by the Engineer shall be employed.

1602.3.5 PE (Polyethelene) Plastic Pipe

All PE pipes when supplied under the specification shall be joined employing either of the following methods:

Butt-Fusion

When pipe supplied under this specification are installed and joined by this method, the work shall be carried out only by well qualified personnel who adhere strictly to prescribed working conditions using tools and procedures recommended by the manufacturer and approved by the Engineer.

- a. Equipment - the equipment needed shall be as described in ASTM D-2657.
- b. General Procedure - The following procedures shall be followed when making butt-

fusion joint:

1. Wipe each pipe-end-clean, inside and outside to remove dirt, water, grease and other

foreign material.

2. Square the end of each pipe section to be fused using a fusing tool. Remove cuttings and

burns from pipe ends.

3. Check line-up of pipe-ends in fusion machine to see that pipe ends meet squarely and

completely over the entire surface to be fused. Two clamps should be used on each end of pipe to be fused for sizes 100 mm and above.

4. Insert the heater plate between the aligned pipe ends. Bring and hold the pipes ends in

contact and allow pipe to heat and soften until a bead of molten plastic roll back from the ends. This bead will be about 1.5 mm to 5.0 mm back from the end of the pipe depending on size. Soften approximately 1.50 mm on all sizes up to 75 mm. On 75 mm to 150 mm heat to 5.0 mm. Softening can be judged by the appearance of the pipe end as the material softens. Both surfaces of the heater plate shall be cleaned and the temperature maintained at 246 degrees C to 260 degrees C (475 degrees F to 500 degrees F.)

5. Carefully remove the pipe ends from the heater plate and remove the plate. If the

softened material sticks to the heater plate, discontinue the joint. Clean heater plate, resquare pipe end and start over.

6. Bring the heated pipe ends together with the specified pressure to form a uniform double

head about 3.0 mm to 5.0 mm wide around the entire circumference of the pipe.

7. Allow the joint to cool and solidify while maintaining the pressure for the specified time.

Inspect the joint for a uniform non-porous appearance. If the joint appears faulty, cut the joint out and repeat the procedure.

1602.4 Method of Measurement

The quantity to be paid under this item shall be the length in metres of pipes in place completed and accepted, measured from end to end of the pipeline~

1602.5 Basis of Payment

The quantity determined as provided above, shall be paid for or the contract price per metre for pipe actually installed and payment shall constitute full compensation for furnishing and installation of all pipes, fittings, closure pieces, bolts, nuts, gaskets, jointing materials and for all labor, equipment, tools and incidentals necessary to complete the work.

Pay Item No. and Name	Unit of Measurement
-----------------------	---------------------

1602-1 Mortar lined and	enamel Mortar
-------------------------	---------------

coated steel pipe

1602-2 Cast Iron Water pipe metre

1602-3 Asbestos-cement

water pipe metre

1602-4 PVC Polyvinyl metre

Chloride pipe 1

602-5 Polyethelene (PE)

Plastic pipe metre

Section VII. Drawings

(SEE ATTACHED PLAN)

Section VIII. Bill of Quantities

BILL OF QUANTITIES
CONSTRUCTION OF WATER SYSTEM

Brgy. Hinipaan, Mercedes, Camarines Norte

Item No.	Scope of Work	Unit	Quantity	Unit Price	TOTAL
I	PIPE TRENCH EXCAVATION	Cu.m.	756.00		
II	FILL AND BACKFILL	Cu.m.	731.27		
III	PIPES AND FITTINGS	LS	1.00		
IV	INSTALLATION OF ONE (1) UNIT TAPSTAND	Unit	1.00		
V	HYDROTESTING AND DISINFECTION	LS	1.00		
VI	BUNKHOUSE	Months	3.00		
VII	PROVISION OF 4x4 PICK UP TYPE SERVICE VEHICLE	Days	15.00		
VIII	OCCUPATIONAL SAFETY AND HEALTH PROGRAM	Lot	1.00		
IX	PROJECT BILLBOARD	Each	1.00		
TOTAL					

Amount in words:

Signature over Printed Name

Date:

***Section IX. Philippine Bidding Documents
Related Forms***

TABLE OF CONTENTS

Bid Form.....	122
Contract Form.....	124
Omnibus Sworn Statement Form	127
Bid Securing Declaration Form	131
Affidavit of Site Inspection.....	134
Affidavit of availability of Key Personnel and Equipment.....	131
Key Personnel’s Certificate of Employment.....	136

Bid Form for Procurement of Infrastructure Projects

[Note: The duly accomplished form shall be submitted with the Bid]

BID FORM

Project Identification No.: *[Insert number]*

To: *HON. RICARTE R. PADILLA*
Governor
PLGU-Camarines Norte

Having examined the Philippine Bidding Documents (PBD) including the Supplemental Bid Bulletin Numbers *[insert numbers]*, the receipt of which is hereby duly acknowledged, we, the undersigned, declare that:

- a) I/We have no reservation to the PBD, including the Supplemental Bid Bulletins, for the Procurement Project *[Project Title]*;
- b) I/We offer to execute the Works for this Contract in accordance with the PBD;
- c) The total price of our Bid in words and figures, excluding any discount offered below, is *[insert information]*
- d) The discounts offered and the methodology for their application, if any, are: *[insert information]*; or indicate N/A if no discount offered
- e) The total bid price in words and figures, after applying the applicable discount, includes the cost of all taxes, such as, but not limited to *[specify the applicable taxes, e.g. (i) value added tax (VAT), (ii) income tax, (iii) local taxes, and (iv) other fiscal levies and duties]*, which are itemized in the Detailed Estimates.
- f) This Bid shall remain valid within a period stated in the PBD, and it shall be binding upon me/us at any time before the expiration of that period;
- g) If our bid is accepted, I/we commit to enter to a contract and provide a performance security in the form, amounts, and within the times prescribed in the PBD, and hereby acknowledge the consequences under the IRR of RA No. 12009 on forfeiture of Bid Security or enforcement of Bid Securing Declaration and on Blacklisting.

Until a formal Contract is prepared and executed, this Bid, together with your written acceptance thereof and your Notice of Award, shall be binding upon the Bidder.

I/We understand that you are not bound to accept the Lowest Calculated Bid or any Bid you may receive.

I/We certify/confirm that we comply with the eligibility requirements pursuant to the PBD.

The undersigned is authorized to submit the bid on behalf of *[Name of the Bidder]* as evidenced by the attached *[State the Written Authority]*.

I/We acknowledge that failure to sign each and every page of this Bid Form, including the attached Schedule of Prices, shall be a ground for the rejection of our bid.

Duly authorized to sign the Bid for and behalf of:

[Insert Bidder's Name]

[Signature over Printed Name]

[Position/Designation]

[Date]

Contract Form

[Note: The duly accomplished form is not required to be submitted with the Bid but shall be submitted within ten (10) days after receiving the Notice of Award]

CONTRACT FOR [Insert Project Title]

THIS CONTRACT executed on the ____ day of _____ 20____ between:

[Name of Procuring Entity], a government agency of the Republic of the Philippines, hereinafter called “the Entity”;

-and-

[Name of Contractor] Filipino of legal age or a company duly organized and existing under the laws of [city and country], with principal office at [insert address], hereinafter called “the Contractor”.

WHEREAS, the Entity invited Bids for certain goods and ancillary services, particularly *[Brief description of Project]*;

WHEREAS, the Contractor submitted a responsive bid and was awarded the contract for the procurement in the total amount of *[Contract price in words and figures, including currency]*, hereinafter referred to as the “Contract Price.”

NOW, THEREFORE, for and in consideration of the foregoing premises, the parties hereby agree as follows:

- 1) Unless otherwise stated, terms and expressions used in this Contract shall have the same meanings as those assigned to them in the Conditions of Contract, which form an integral part of this Contract.
- 2) The following documents as required by the Implementing Rules and Regulations of Republic Act No. 12009 shall be deemed to form and be read and construed as integral part of this Contract, *viz.*:
 - a) Philippine Bidding Documents (PBD);
 - i. Drawings/Plans;
 - ii. Scope of Work;
 - iii. Invitation to Bid;
 - iv. Instructions to Bidders;
 - v. Bid Data Sheet;
 - vi. Bid Form, including all the documents/statements contained in the Bidder’s bidding envelopes, as annexes, and all other documents submitted (e.g., Bidder’s response to request for clarifications on the bid), including corrections to the bid, if any, resulting from the Procuring Entity’s bid evaluation;
 - vii. Bill of Quantities;
 - viii. General and Special Conditions of Contract;
 - ix. Supplemental Bid Bulletins, if any; and
 - x. Other contract documents that may be required by existing laws and/or the Entity.
 - b) Winning bidder’s bid, including the Eligibility Requirements, Technical and Financial Proposals, and all other documents or statements submitted;
 - c) Performance Security;

- d) Notice of Award of Contract; and the Bidder's Conforme thereto; and
 - e) Other contract documents that may be required by existing laws and/or the Procuring Entity concerned in the PBD, such as but not limited to the Notice to Proceed and Warranty Security.
- 3) In consideration of the Contract Price of [*Contract Price in words and figures*], or such other sums as may be determined in accordance with the terms of the Contract, the Supplier agrees to deliver and perform the items and related services for the [*Project Title*] described herein in accordance with the terms and conditions specified in the Contract and its annexed documents.
 - 4) The [*Name of the Procuring Entity*] agrees to pay the above-mentioned sum to the Supplier in accordance with the schedule and manner provided in the Bidding Documents and its annexes.
 - 5) Any dispute, difference, or claim arising out of or relating to this Contract, including its existence, validity, interpretation, breach, or termination thereof, may be submitted to arbitration or other form of alternative dispute resolution in accordance with the applicable law, such as Republic Act (RA) No. 9285 (Alternative Dispute Resolution Act of 2004) or Executive Order No 1008, series 1985 (Construction Industry Arbitration Law).

IN WITNESS WHEREOF, the parties hereto have caused this Contract to be executed in accordance with the laws of the Republic of the Philippines on the day and year first above written

For the Procuring Entity
 Head of the Procuring Entity or Duly
 Authorized Representative

For the Bidder
 Duly authorized to sign the Contract for
 and behalf of [*Bidders Name*]:

[*Signature over Printed
 Name*][*Position/Designation*]
 [*Date*]

[*Signature over Printed Name*]
 [*Position/Designation*]
 [*Date*]

Signed in the presence of:

[*Name and Signature*]
 Witness – Procuring Entity

[*Name and Signature*]
 Witness- Supplier

ACKNOWLEDGMENT

BEFORE ME, A Notary Public for and in the _____, City/Province of _____, this _____ day of _____, 20____, personally appeared the above-named persons who have satisfactorily proven to me their identity, through their identifying documents written below their names and signatures, that they are the same persons who executed and voluntarily signed the foregoing instrument consisting of ____ pages, including this page where this Acknowledgement is written, which they acknowledged before me as their free and voluntary act and deed.

WITNESS MY HAND AND SEAL this ____ day of *[month]* *[year]*.

NAME OF NOTARY PUBLIC

Notarial Commission No. _____

Notary Public for _____ until _____

Roll of Attorneys No. _____

PTR No. __, *[date issued]*, *[place issued]*

IBP No. __, *[date issued]*, *[place issued]*

Doc. No. _____

Page No. _____

Book No. _____

Series of _____

Omnibus Sworn Statement Form

[Note: The duly accomplished form shall be submitted with the Bid]

REPUBLIC OF THE PHILIPPINES)
CITY/MUNICIPALITY OF _____) S.S.

OMNIBUS SWORN STATEMENT

I, *[Name of Affiant]*, of legal age, *[Civil Status]*, *[Nationality]*, and with residence at *[Address of Affiant]*, after having been duly sworn in accordance with law, do hereby depose and state that:

1) *Select one, delete the others:*

- *If sole proprietorship:* I am the sole proprietor or authorized representative of *[Name of Bidder]* with office address at *[Address of Bidder]*;
- *If partnership, corporation, cooperative, or joint venture:* I am the duly authorized and designated representative of *[Name of Bidder]* with office address at *[Address of Bidder]*;
- *If individual consultant not registered under a sole proprietorship, in case of Consulting Services:* I am the individual consultant or authorized representative of *[Name of Bidder]* with office address at *[Address of Bidder]*;

2) *Select one, delete the others:*

- *If sole proprietorship:* As the owner and sole proprietor or authorized representative of *[Name of Bidder]*, I have full power and authority to do, execute and perform any and all acts necessary to participate, submit the bid, and to sign and execute the ensuing contract for *[Project Title]* of the *[Name of the Procuring Entity]**[insert “as supported by the attached duly notarized Special Power of Attorney” for authorized representative]*;
- *If partnership, corporation, cooperative, or joint venture:* I am granted full power and authority to do, execute and perform any and all acts necessary to participate, submit the bid, and to sign and execute the ensuing contract for *[Project Title]* of the *[Name of the Procuring Entity]*, as supported by the attached duly notarized Special Power of Attorney, Board/Partnership Resolution, or Secretary’s Certificate, whichever is applicable;
- *If individual consultant not registered under a sole proprietorship, in case of Consulting Services:* As the individual consultant or authorized representative of *[Name of Bidder]*, I have full power and authority to do, execute and perform any and all acts necessary to participate, submit the bid, and to sign and execute the ensuing contract for *[Project Title]* of the *[Name of the Procuring Entity]*, as supported by the attached duly notarized Special Power of Attorney *for authorized representative*;

3) *[Name of Bidder]* is not “blacklisted” or barred from bidding by the Government of the Philippines or any of its agencies, offices, corporations, or Local Government Units, foreign government/foreign or international financing institution whose blacklisting rules have been recognized by the Government

Procurement Policy Board; by itself or by relation, membership, association, affiliation, or controlling interest with another blacklisted person or entity;

- 4) Each of the documents submitted in satisfaction of the bidding requirements is an authentic copy of the original, complete, and all statements and information provided therein are true and correct;
- 5) *[Name of Bidder]* is authorizing the Head of the Procuring Entity or its duly authorized representative(s) to verify all the documents submitted;
- 6) *Select one, delete the others:*
 - *If sole proprietorship* : The *[Name of Bidder]* and its spouse are not related by consanguinity or affinity up to the third civil degree to the Head of the Procuring Entity, Procurement Agent (if engaged), End-User or Implementing Unit, project consultants, head of the Project Management Office, or the members of the Bids and Awards Committee (BAC), the Technical Working Group, and the BAC Secretariat;
 - *If partnership* : The partnership itself and the partners of *[Name of Bidder]* are not related by consanguinity or affinity up to the third civil degree to the Head of the Procuring Entity, Procurement Agent (if engaged), End-User or Implementing Unit, project consultants, head of the Project Management Office, or the members of the Bids and Awards Committee (BAC), the Technical Working Group, and the BAC Secretariat;
 - *If cooperative*: The cooperative itself and members of the board of directors, general manager, or chief executive officer of *[Name of Bidder]* are not related by consanguinity or affinity up to the third civil degree to the Head of the Procuring Entity, Procurement Agent (if engaged), End-User or Implementing Unit, project consultants, head of the Project Management Office, or the members of the Bids and Awards Committee (BAC), the Technical Working Group, and the BAC Secretariat;
 - *If corporation, or joint venture*: The corporation or joint venture itself, and officers, directors, and controlling stockholders of *[Name of Bidder]* are not related by consanguinity or affinity up to the third civil degree to the Head of the Procuring Entity, Procurement Agent (if engaged), End-User or Implementing Unit, project consultants, head of the Project Management Office, or the members of the Bids and Awards Committee (BAC), the Technical Working Group, and the BAC Secretariat;
 - *If individual consultant not registered under a sole proprietorship, in case of Consulting Services*: The individual consultant and its spouse are not related by consanguinity or affinity up to the third civil degree to the Head of the Procuring Entity, Procurement Agent (if engaged), End-User or Implementing Unit, project consultants, head of the Project Management Office, or the members of the Bids and Awards Committee (BAC), the Technical Working Group, and the BAC Secretariat;
- 7) It is understood that failure to faithfully disclose its relationship with the HoPE, members of the BAC, the TWG, and the BAC Secretariat, the head of the PMO or the end-user unit or implementing unit, and the project consultants of the Procuring Entity, or of the procurement agent by consanguinity or affinity up to the third civil degree, as well as its submission of beneficial ownership information containing false entries shall be subject to blacklisting under Section 100 of the IRR of RA No. 12009, without prejudice to criminal and civil liabilities under applicable laws, including their accessory penalties, if any.

Select one, delete the rest:

- *In case of corporations: [Name of Bidder]* declares its beneficial ownership information consistent with its updated General Information Sheet or Beneficial Ownership Declaration Form or any other document duly submitted to the SEC and has maintained a valid and updated file therein in compliance with Sections 20.2.9.1, 81, and 82 of the IRR of Republic Act (RA) No. 12009.
 - *In case of Foreign Bidders: [Name of Bidder]* submitted an appropriate equivalent document in English issued by the country of the bidder concerned in accordance with Section 20.2.9.2 of the IRR of RA No. 12009.
- 8) *[Name of Bidder]* complies with existing labor laws and standards; and
- 9) *[Name of Bidder]* is aware of and has undertaken the following responsibilities as a Bidder:
- a) Carefully examine all of the Bidding Documents;
 - b) Acknowledge all conditions, local or otherwise, affecting the implementation of the Contract;
 - c) Made an estimate of the facilities available and needed for the contract to be bid, if any; and
 - d) Inquire or secure Supplemental Bid Bulletin(s) issued for the *[Project Title]*.
- 10) *[Name of Bidder]* did not give or pay directly or indirectly, any commission, amount, fee, or any form of consideration, pecuniary or otherwise, to any person or official, personnel or representative of the government in relation to any procurement project or activity.
- 11) In case advance payment was made or given to *[Name of Bidder]*, failure to perform or deliver any of the obligations and undertakings in the contract shall be sufficient grounds to constitute criminal liability under existing laws.

IN WITNESS WHEREOF, I have hereunto set my hand this ___ day of ___, 20__ at _____, Philippines.

Duly authorized to sign the Bid for and behalf of:

[Insert Bidder's Name]

[Affiant's Signature over Printed Name]

[Position/Designation]

[Date]

JURAT

SUBSCRIBED AND SWORN to before me this _____ day of *[month]* *[year]* at *[place of execution]*, Philippines. Affiant/s is/are personally known to me and was/were identified by me through competent evidence of identity as defined in the 2004 Rules on Notarial Practice (A.M. No. 02-8-13-SC). Affiant/s exhibited to me

his/her *[insert type of government identification card used]*, with his/her photograph and signature appearing thereon, with no. _____.

WITNESS MY HAND AND SEAL this ____ day of *[month]* *[year]*.

NAME OF NOTARY PUBLIC

Notarial Commission No. _____

Notary Public for _____ until _____

Roll of Attorneys No. _____

PTR No. __, *[date issued]*, *[place issued]*

IBP No. __, *[date issued]*, *[place issued]*

Doc. No. _____

Page No. _____

Book No. _____

Series of _____.

Bid Securing Declaration Form

*[The duly accomplished form shall be submitted with the Bid
if bidder opts to provide this type of bid security]*

REPUBLIC OF THE PHILIPPINES)
CITY/MUNICIPALITY OF _____) S.S.

BID SECURING DECLARATION

Project Identification No.: [Number]

To: *HON. RICARTE R. PADILLA*
Governor
PLGU-Camarines Norte

I/We, the undersigned, declare that:

- 1) I/We understand that, according to your conditions, bids must be supported by a Bid Security, which may be in the form of a Bid Securing Declaration;
- 2) I/We accept that:
 - a) I/We shall enter into contract with the Procuring Entity and furnish the required performance security within ten (10) calendar days as indicated in the Bidding Documents, from receipt of the Notice of Award;
 - b) I/we will be automatically disqualified from bidding for any procurement contract with any Procuring Entity upon receipt of your Blacklisting Order; and
 - c) I/We will pay the applicable fine within fifteen (15) days from receipt of the written demand by the Procuring Entity for the commission of acts resulting to the enforcement of the Bid Securing Declaration under Sections 52.2 (a), 63.2, 69.1 and 100, except 100.3 (c), of the IRR of RA No. 12009; without prejudice to other legal action the government may undertake;

	<i>Applicable Fine</i>
a) in the case of a single bidder	<ol style="list-style-type: none">i) two percent (2%) of the Approved Budget for the Contract (ABC); orii) the difference between the evaluated bid price and the ABC whichever is higher
b) in the case of multiple bidders	<ol style="list-style-type: none">i) two percent (2%) of the ABC; orii) the difference between the evaluated bid prices with the bidder with Lowest Calculated/Highest Rated Bid and the bidder with the next Lowest

	Calculated/Highest Rated Bid, and so on whichever is higher
c) in case of violations committed prior to the opening of the financial envelope	i) a fixed amount of two percent of the ABC,

- 3) I/We understand that this Bid Securing Declaration shall cease to be valid on the following circumstances:
- a) Upon expiration of the bid validity period, or any extension thereof pursuant to your request;
 - b) I am/we are declared ineligible or post-disqualified upon receipt of your notice to such effect, and (i) I/we failed to timely file a request for reconsideration or (ii) I/we filed a waiver to avail of said right;
 - c) I am/we are declared the bidder with the *[Insert Award Criterion¹]* and I/we have furnished the performance security and signed the Contract.

IN WITNESS WHEREOF, I/We have hereunto set my/our hand/s this ____ day of *[month]* *[year]* at *[place of execution]*.

Duly authorized to sign the Bid for and behalf of:

[Insert Bidder's Name]

[Signature over Printed Name]

[Position/Designation]

[Date]

JURAT

SUBSCRIBED AND SWORN to before me this ____ day of [month] [year] at [place of execution], Philippines. Affiant/s is/are personally known to me and was/were identified by me through competent evidence of identity as defined in the 2004 Rules on Notarial Practice (A.M. No. 02-8-13-SC). Affiant/s exhibited to me his/her [insert type of government identification card used], with his/her photograph and signature appearing thereon, with no. _____.

WITNESS MY HAND AND SEAL this ____ day of [month] [year].

NAME OF NOTARY PUBLIC

Notarial Commission No. _____

Notary Public for _____ until _____

Roll of Attorneys No. _____

PTR No. __, [date issued], [place issued]

IBP No. __, [date issued], [place issued]

Doc. No. _____

Page No. _____

Book No. _____

Series of _____

AFFIDAVIT OF SITE INSPECTION

I, (Representative of the Bidder) , of legal age, (civil status) , Filipino and residing at (Address of the Representative) , under oath, hereby depose and say:

1. That I am the (Position in the Bidder) of the (Name of the Bidder) , with office at (Address of the Bidder) ;
2. That I have inspected the site for (Name of the Contract) , located at (location of the Contract) ;
3. That I am making this statement as part of the requirement for the Technical Proposal of the (Name of the Bidder) for (Name of the Contract) .

IN FAITH WHEREOF, I hereby affix my signature this day of , 20 at , Philippines.

AFFIANT

Witness:

SUBSCRIBED AND SWORN TO before me this , day of 20 , affiant exhibiting to me his/her Community Tax Certificate No. issued on at , Philippines.

(Notary Public)

Until	_____
PTR No.	_____
Date	_____
Place	_____
TIN	_____

Doc. No. _____
Page No. _____
Book No. _____
Series of _____

Bids and Awards Committee
Provincial Government of Camarines Norte
Provincial Capitol Building
Daet, Camarines Norte

AFFIDAVIT OF AVAILABILITY OF KEY PERSONNEL AND EQUIPMENT

I, _____ of legal age, Filipino, married/single/widow, and, a resident of _____, owner/proprietor of _____ after having been duly sworn to in accordance with law, depose and declare;

1. That I/we have engage and contracted the service of Engr. _____ (herein called the Resident/Project Engineer), a Registered Civil Engineer with Professional License No. _____ issued on _____ and who has paid his Professional Tax for the Current Year _____;
2. That the said Engineer shall be appointed and designated as our Resident/Project Engineer to personally manage and supervise the construction.
3. That the said Engineer shall employ the best care, skill and ability in supervising the project in accordance with the Contract Agreement, contract plan, and other provisions embodied in the proposed contract;
4. That the said Engineer shall be personally present at the jobsite to supervise all the phase of the construction work at all time;
5. That all other key personnel are available for the project;
6. That equipment needed for the project, are likewise available;
7. That any willful violation on my/our part of the herein condition may prejudice my/our standing as a reliable contractor in future biddings in your office.

IN WITNESS WHEREOF, I have here unto set my hands this _____ day of _____, 20____ at _____, Philippines.

Affiant's Printed Name and Signature

WITNESSES:

SUBSCRIBED AND SWORN to before me this _____ day of _____, 20____ affiant exhibiting to me his/her Resident Certificate No.: _____ issued _____ at _____.

Notary Public

Doc No.: _____
Page No.: _____
Book No.: _____
Series of: _____

Bids and Awards Committee
 Provincial Government of Camarines Norte
 Provincial Capitol Building
 Daet, Camarines Norte

KEY PERSONNEL’S CERTIFICATE OF EMPLOYMENT

_____ *Date*

Dear Sir / Madame:

I am (Name of Nominee) a Licensed Engineer with Professional License No. _____ issued on (date of issuance) at (place of issuance) .

I hereby certify that (Name of Bidder) has engaged my services as (Designation) for (Name of the Contract) , if awarded to it.

As (Designation) , I supervised the following completed projects similar to the contract under bidding:

<u>NAME OF PROJECT</u>	<u>OWNER</u>	<u>COST</u>	<u>DATE COMPLETED</u>
_____	_____	_____	_____
_____	_____	_____	_____
_____	_____	_____	_____
_____	_____	_____	_____

At present, I am supervising the following projects:

<u>NAME OF PROJECT</u>	<u>OWNER</u>	<u>COST</u>	<u>DATE COMPLETED</u>
_____	_____	_____	_____
_____	_____	_____	_____
_____	_____	_____	_____
_____	_____	_____	_____

In case of my separation for any reason whatsoever from the above-mentioned Contractor, I shall notify the (Name of the Procuring Entity) at least twenty one (21) days before the effective date of my separation.

As (Designation), I know I will have to stay in the job site all the time to supervise and manage the Contract works to the best of my ability, and aware that I am authorized to handle only one (1) contract at a time.

I do not allow the use of my name for the purpose of enabling the above-mentioned Contractor to qualify for the Contract without any firm commitment on my part to assume the post of (Designation) therefore, if the contract is awarded to him since I understand that to do so will be a sufficient ground for my disqualification as (Designation) in any future (Name of the Procuring Entity) bidding or employment with any Contractor doing business with the (Name of the Procuring Entity).

(Signature of Engineer)

WITNESSES:

DRY SEAL

Republic of the Philippines)
_____) S.S.

SUBSCRIBED AND SWORN TO before me this _____ day of _____ 20__ affiant exhibiting to me his Residence Certificate No. _____ issued on _____ at _____.

NOTARY PUBLIC
PTR No.: _____
Issued at: _____
Issued on: _____
Until 31 December 20____

Doc. No.: _____;
Page No. : _____;
Book No.: _____;
Series of _____;

Section X. Checklist of Technical and Financial Documents

Checklist of Technical and Financial Documents

Note: This shall serve as a guide in the preparation of the bid submission. Any inconsistencies between the Bid Data Sheet (BDS) and this Checklist, the BDS shall prevail.

I. TECHNICAL COMPONENT ENVELOPE

Class “A” Documents

Legal Documents

- (a) Valid and updated PhilGEPS Registration Certificate (Platinum Membership) (all pages) (In compliance with Section 20.2.9.1 of IRR of RA No. 12009); and

Technical Documents

- (b) Statement of the prospective bidder of all its ongoing government and private contracts, including contracts awarded but not yet started, if any, whether similar or not similar in nature and complexity to the contract to be bid; **and**
- (c) Statement of the bidder’s Single Largest Completed Contract (SLCC) similar to the contract to be bid, except under conditions provided under the rules; (This statement shall be supported by contracts, owner’s final acceptance or equivalent document, and CPES rating sheets, if applicable. These supporting documents shall be numbered and tabbed in the same sequence as the list of contracts appears in this statement.); **and**
- Special PCAB License in case of Joint Ventures/Consortium; **and** registration for the type and cost of the contract to be bid (GPPB Resolution No.15-2021); **and**
- (d) Original copy of Bid Security. If in the form of a Surety Bond, submit also a certification issued by the Insurance Commission;
Or Original copy of Notarized Bid Securing Declaration; **and**
- (e) Project Requirements, which shall include the following:
 - a. Organizational chart for the contract to be bid;
 - b. List of contractor’s key personnel (*e.g.*, Project Manager, Project Engineers, Materials Engineers, and Foremen), to be assigned to the contract to be bid, with their complete qualification and experience data;
 - c. List of contractor’s major equipment units, which are owned, leased, under purchase agreements, supported by proof of ownership or certification of availability of equipment from the equipment lessor/vendor for the duration of the project, as the case may be
 - d. Key Personnel’s Certificate of Employment (notarized)
 - e. Original duly signed Omnibus Sworn Statement (OSS);

and if applicable, Original Notarized Secretary's Certificate in case of a corporation, partnership, or cooperative; or Original Special Power of Attorney of all members of the joint venture giving full power and authority to its officer to sign the OSS and do acts to represent the Bidder.

Financial Documents

- (f) The prospective bidder's audited financial statements, showing, among others, the prospective bidder's total and current assets and liabilities, stamped "received" by the BIR or its duly accredited and authorized institutions, for the preceding calendar year which should not be earlier than two (2) years from the date of bid submission
- (g) The prospective bidder's computation of Net Financial Contracting Capacity (NFCC).

Class "B" Documents

- (h) If applicable, duly signed joint venture agreement (JVA) in accordance with RA No. 4566 and its IRR in case the joint venture is already in existence;

II. FINANCIAL COMPONENT ENVELOPE

- (i) Original of duly signed and accomplished Financial Bid Form; **and**

Other documentary requirements under RA No. 12009

- (j) Original of duly signed Bid Prices in the Bill of Quantities; **and**
- (k) Duly accomplished Detailed Estimates Form, including a summary sheet indicating the unit prices of construction materials, Dayworks Schedule, labor rates, and equipment rentals used in coming up with the Bid; **and**
- (l) Cash Flow by Quarter.

DAYWORKS SCHEDULE - LABOR

Project Name: Rebidding for the Design and Build of _____

NO	TYPE OF LABOR	UNIT	RATE
L01	Foreman	Hour	
L03	Heavy Equipment Operator	Hour	
L06	Driver	Hour	
L07	Skilled Laborer	Hour	
L10	Other (specify)	Hour	

Uncontrolled when printed and emailed

DAYWORKS SCHEDULE - MATERIALS

Project Name: Rebidding for the Design and Build of _____

NO	TYPE OF MATERIALS/SPECIFICATION	UNIT	RATE
M01	Aggregate Subbase Course	Cu.M.	
M02	Portland Cement	Bag	
M22	Others (Specify)		

Uncontrolled when printed and emailed



FEB 07 2025

DEPARTMENT ORDER) **SUBJECT:** **Guidelines in the Preparation of**
) **Program of Works (POW) and**
) **Approved Budget for the Contract**
NO. 30) **(ABC)**
Series of 2025 *fy 2/10/2025*

In line with the Department's Quality Policy to deliver right projects at the right cost, the following policies, guidelines, and procedures relative to the preparation of cost estimates such as the Program of Works (POW) and Approved Budget for the Contract (ABC) are hereby established.

The POW and ABC, together with the Detailed Unit Price Analysis (DUPA), shall be prepared based on the design plans for the project which has been duly approved by the authorized officials in accordance with existing regulations. All pay items to be incorporated in the POW and ABC shall conform to the most recent editions of the Department of Public Works and Highways (DPWH) Standard Specifications for Highways, Bridges, and Airports (Volume II), DPWH Standard Specifications for Public Works Structures (Buildings, Ports and Harbors, Flood Control and Drainage Structures and Water Supply Systems) (Volume III), and latest issuances on Standard Specifications.

I. Approved Budget for the Contract (ABC)

The ABC shall consist of both Direct Cost and Indirect Cost.

A. The **Direct Cost** shall consist of the following:

1. **For Material Component** – the price of materials to be used in doing the works called for shall include, inter alia, the following:
 - 1.1. Cost at source (base price), including processing, crushing, stockpiling, loading, royalties, local taxes, construction and/or maintenance of haul roads, etc.
 - 1.2. Expenses for hauling from source to project site
 - 1.3. Handling expenses
 - 1.4. Storage expenses
 - 1.5. Allowance for wastages and/or losses, not to exceed 5% of materials requirement
 - 1.6. Allowance for swell/shrinkage of materials (e.g., sand, gravel, subbase/base course, etc.)



2. **For Labor Component** – the cost of labor shall include the following:
 - 2.1. Salaries and wages, as authorized by the Department of Labor and Employment (DOLE), issued by the DPWH through a memorandum.
 - 2.2. Fringe benefits, such as vacation and sick leaves, benefits under the Workmen’s Compensation Act, GSIS and/or SSS contributions, allowances, 13th month pay, bonuses, etc.
3. **For Equipment Component** – the equipment expenses shall comply with the following:
 - 3.1. Rental rates of equipment shall be based on the current Association of Carriers and Equipment Lessors (ACEL) Equipment Guidebook approved for use by the DPWH. Rental rates of equipment not indicated in the ACEL Equipment Guidebook shall be taken from the rental rates prepared by the Bureau of Equipment (BOE). For simplicity in computation, the operated rental rates are preferred over the bare rental rates as the former includes operator’s wages, fringe benefits, fuel, oil, lubricants, and equipment maintenance. The make, model, and capacity of the equipment to be utilized should be indicated in the DUPA.
 - 3.2. Mobilization/Demobilization pay item shall be calculated based on the equipment requirements of the project stipulated in the proposal and contract booklet. The cost of mobilization and demobilization shall not exceed 1% of the Estimated Direct Cost (EDC) of all programmed pay items that are civil works in nature, including those pay items under Facilities for the Engineers and Other General Requirements that are civil work in nature. However, in exceptional circumstances where the mobilization and demobilization cost exceed the prescribed 1% threshold, the DUPA reflecting the actual computed mobilization and demobilization costs shall be approved, duly signed, by the approving authority, in accordance with the latest limits of delegated authority governing the approval of POW and ABC. A copy of the approved DUPA for Mobilization/Demobilization, along with the corresponding POW and ABC, must be submitted to the BOC within fifteen (15) calendar days from the date of approval.
 - 3.3. Permits and Clearances pay item shall include the cost of securing MMDA permit, LGU permits, Bureau of Fire Protection Clearance, and other government fees.

B. The **Indirect Cost** shall consist of the following:

1. **Overhead, Contingencies, and Miscellaneous (OCM) Expenses:**
 - 1.1. Overhead Expense shall be 7% to 11% of the EDC, and shall include the following:
 - 1.1.1. Engineering and administrative supervision
 - 1.1.2. Transportation allowances



- 1.1.3. Office expenses (e.g., for the rental of office and quarters, service vehicle, office equipment and supplies, power and water consumption, communication and maintenance)
- 1.1.4. Premium on Contractor’s All Risk Insurance (CARI)
- 1.1.5. Financing cost such as:
 - a. Premium on Bid Security
 - b. Premium on Performance Security
 - c. Premium on Surety for Advance Payment
 - d. Premium on Warranty Security (one year)
- 1.2. Contingencies shall be 0.5% to 3% of the EDC, and shall include expenses for monthly/weekly meetings, coordination meetings with other stakeholders, billboards (excluding Project Billboard/Signboard required by the DPWH and other Government Agencies such as: COA, DENR, etc., which shall be programmed under Part B - Other General Requirements), stages during the groundbreaking and inauguration ceremonies, and unforeseen/other events relative thereto.
- 1.3. Miscellaneous Expenses shall be 0.5% to 1% of the EDC, and shall include laboratory tests for quality control and plan preparation.
- 2. **Contractor’s Profit (CP)** shall be 8% of the EDC for projects with EDC of above PhP 5 Million and 10% for projects with EDC of PhP 5 Million and below.

For ease of calculation, the mark-up percentages for OCM and CP, based on the EDC, shall be specified in the following table.

Estimated Direct Cost (EDC)	OCM (% of EDC)	CP (% of EDC)	Total (% of EDC)
Up to PhP 5 Million	15	10	25
Above PhP 5 Million to PhP 50 Million	12	8	20
Above PhP 50 Million to PhP 150 Million	10	8	18
Above PhP 150 Million	8	8	16

The applicability of OCM and CP for pay items under Facilities for the Engineer (Part A) and Other General Requirements (Part B) are set forth in **Annexes A and B**.

- 3. **Value Added Tax (VAT)** Component – shall be a percentage of the sum of the EDC, OCM, and CP. The applicable rate shall be based on the latest guidelines issued by the DPWH Finance Service, in adherence to the provisions of the National Internal Revenue Code and its amendments, wherein the



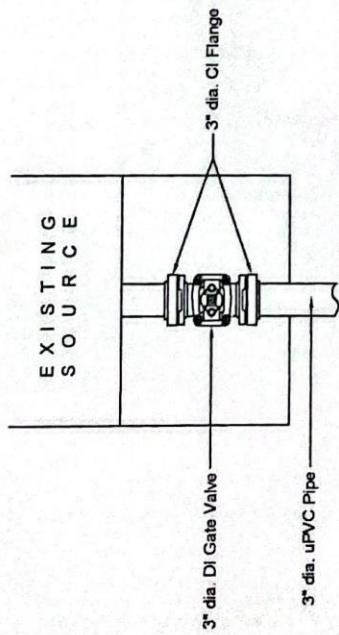

DETAIL OF SOURCE
Scale: NTS

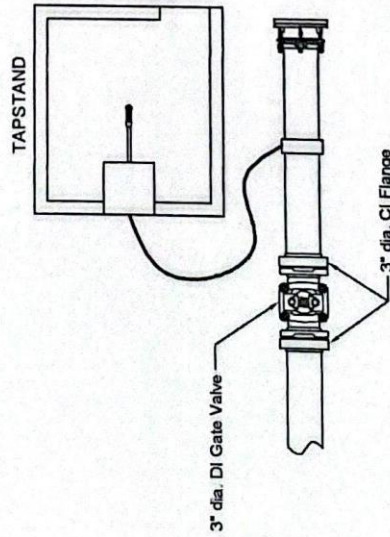

DETAIL OF GATE VALVE AND TAPSTAND
Scale: NTS

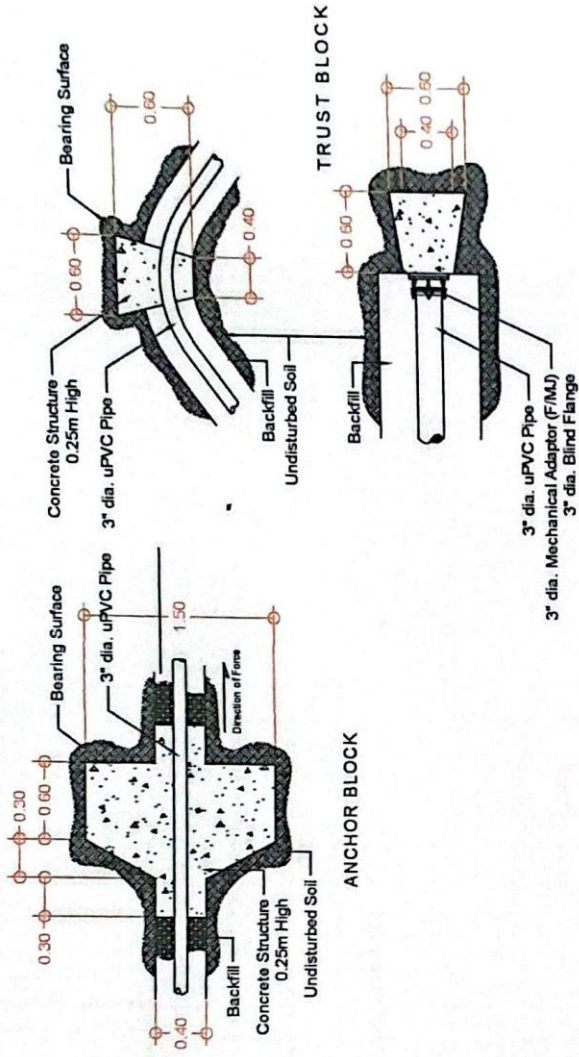

DETAIL OF ANCHOR AND TRUST BLOCK
Scale: 1:50

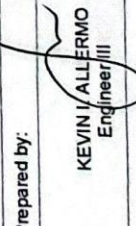
<p>CONSTRUCTION OF WATER SYSTEM</p> <p>Brgy. Hinipaan, Mercedes, Camarines Norte</p>	<p>Prepared by:</p> <p>KEVIN J. ALLERMO</p> <p>Engineer/III</p>	<p>Checked by:</p> <p>SAYILEE V. MENDOZA</p> <p>Chief Planning Division</p>	<p>Reviewed by:</p> <p>BELLA B. ORIOLA</p> <p>Chief Construction Division / Assistant Provincial Engineer</p>	<p>Recommending Approval:</p> <p>JOHN WYVIL S. TOBIAS</p> <p>Provincial Engineer</p>	<p>Approved by:</p> <p>RICHARTE S. PADILLA</p> <p>Governor</p>	<p>SHEET NO</p> <p>2 / 9</p>
						

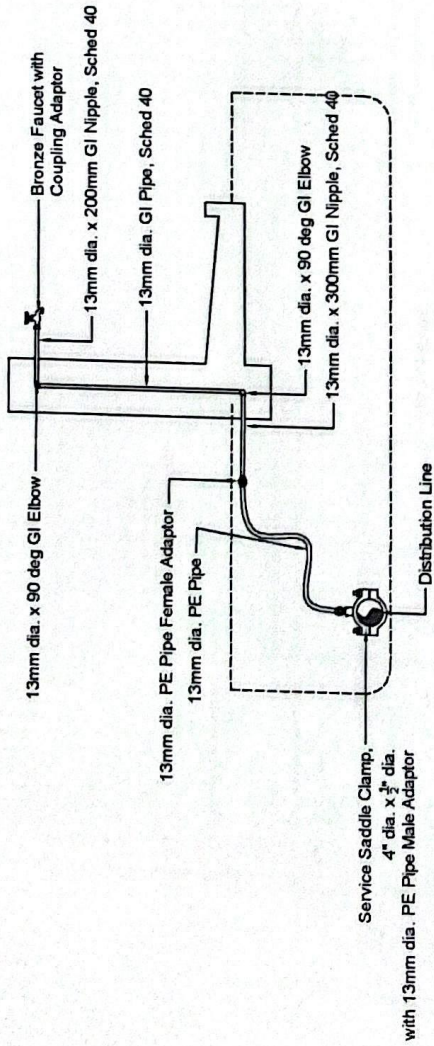

PLUMBING DETAILS

TOP VIEW

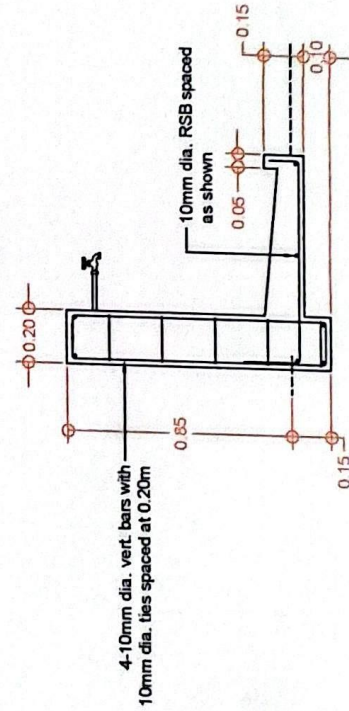
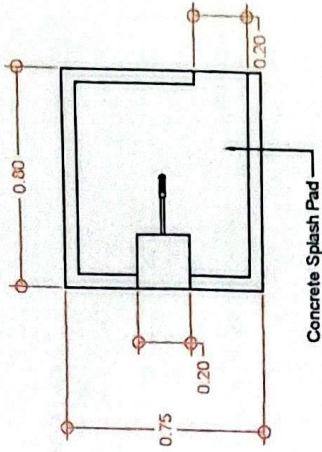

TYPICAL SIDE VIEW

FRONT VIEW

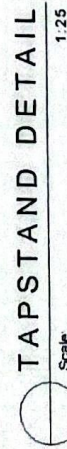
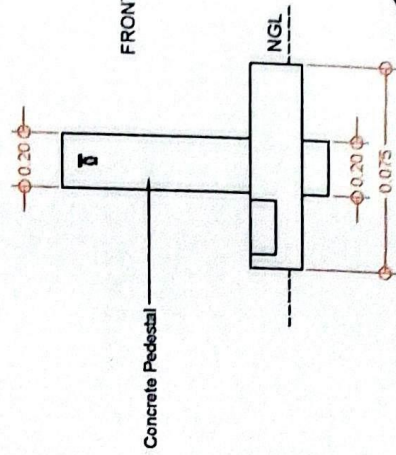

<p>CONSTRUCTION OF WATER SYSTEM Brgy. Hinipaan, Mercedes, Camarines Norte</p>	<p>Prepared by: KEVIN J. ALLERMO Engineer III</p>	<p>Checked by: SAHLEE T. YABDO Chief/Planning Division</p>	<p>Reviewed by: BELLA B. ORIOLA Chief/Construction Division / Assistant Provincial Engineer</p>	<p>Recommending Approval: JOHN MARVIL S. TOBIAS Provincial Engineer</p>	<p>Approved by: RICARTE R. PADILLA Governor</p>	<p>SHEET NO 3 / 9</p>
---	---	--	---	---	---	---------------------------

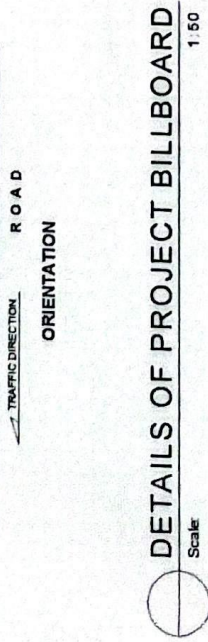
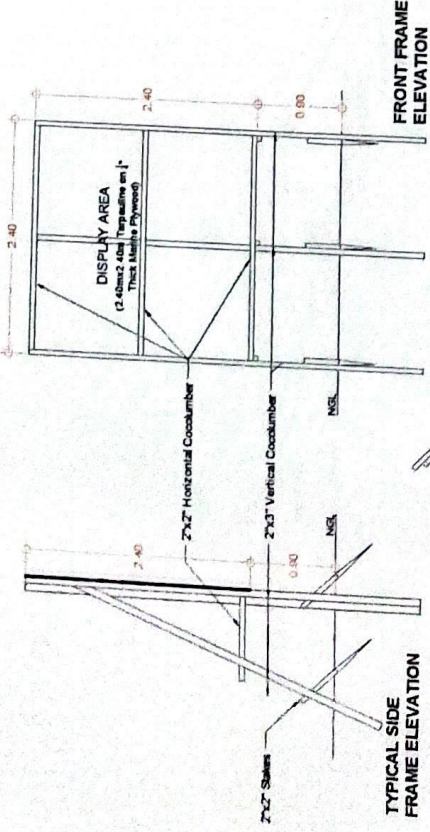

DETAILS OF PROJECT BILLBOARD
Scale: 1:50

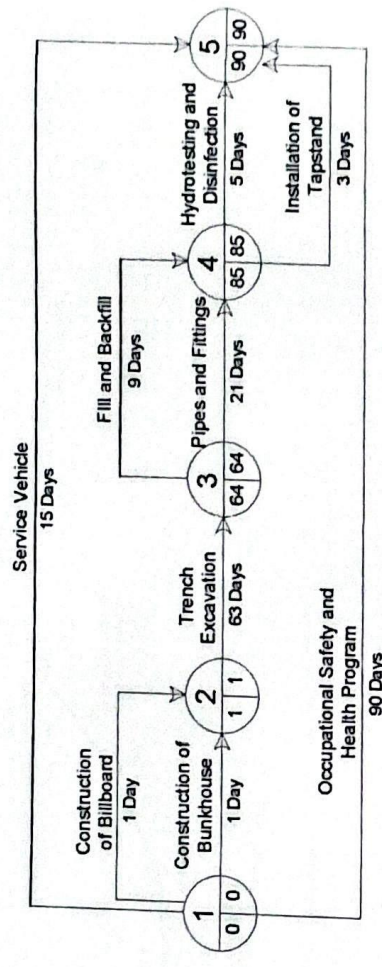

PERT CPM
Scale: NTS

<p>CONSTRUCTION OF WATER SYSTEM 379y. Hinipaan, Mercedes, Camarines Norte</p>	<p>Prepared by: <i>Kevin J. Allermo</i> KEVIN J. ALLERMO Engineer, III</p>	<p>Checked by: <i>Shalee P. Arto</i> SHALEE P. ARTO Chief Planning Division</p>	<p>Reviewed by: <i>Bella B. Oriola</i> BELLA B. ORIOLA Chief Construction Division / Assistant Provincial Engineer</p>	<p>Recommending Approval: <i>John Marvil S. Tobias</i> JOHN MARVIL S. TOBIAS Provincial Engineer</p>	<p>Approved by: <i>Ricarter Padilla</i> RICARTER PADILLA Governor</p>	<p>SHEET NO 4 / 9</p>
---	--	---	--	--	---	----------------------------------

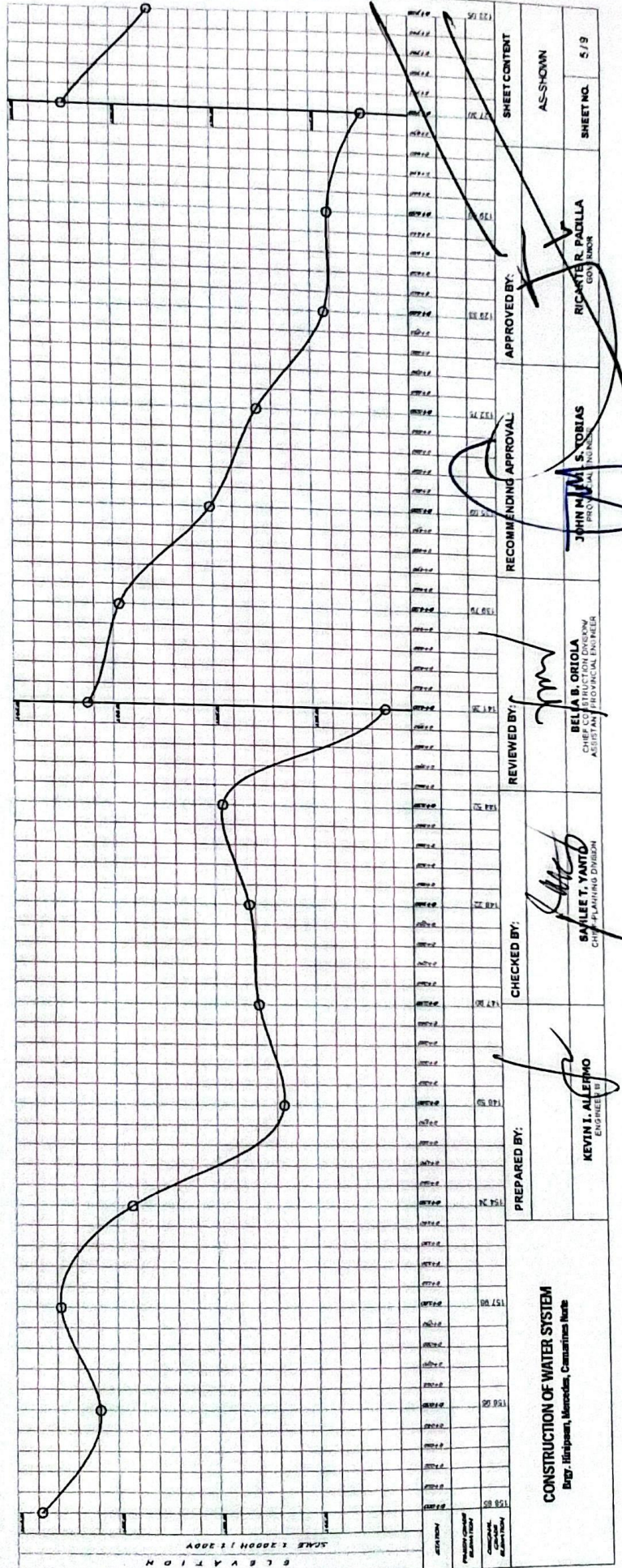
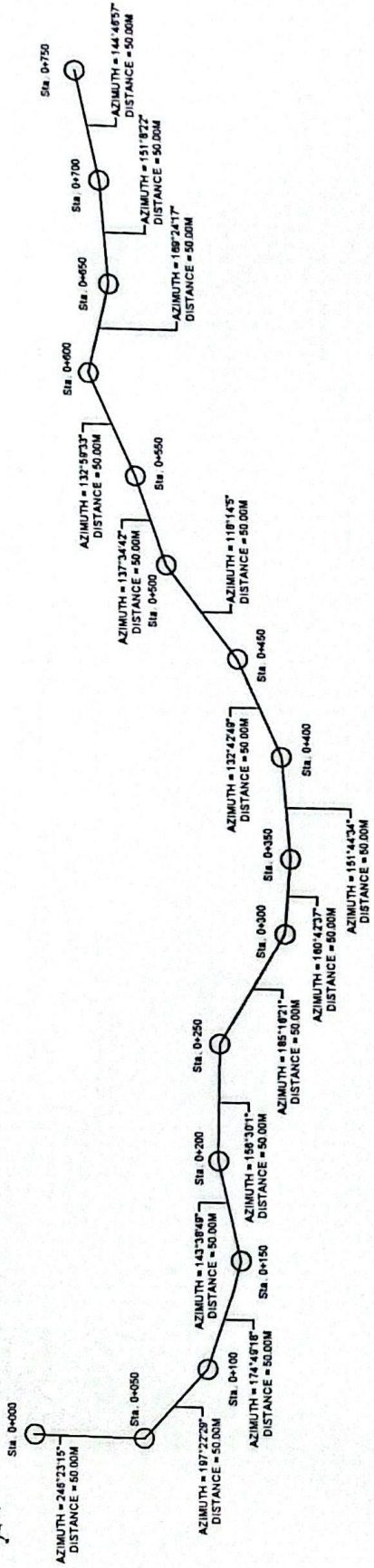

PREPARED BY: KEVIN T. ALLERHO ENGINEER	CHECKED BY: SAULEET YANTI CIVIL PLANNING DIVISION	REVIEWED BY: BELLA B. ORIOLA CIVIL ENGINEER ASSISTANT MECHANICAL ENGINEER	RECOMMENDING APPROVAL: JOHN M. S. TOBIAS PROFESSIONAL ENGINEER	APPROVED BY: RICARTER PADILLA GOVERNOR	SHEET CONTENT: AS-SHOWN SHEET NO. 5/9
--	---	--	--	--	---

CONSTRUCTION OF WATER SYSTEM
 Brgy. Itinipoun, Marosoa, Cagayan Norte

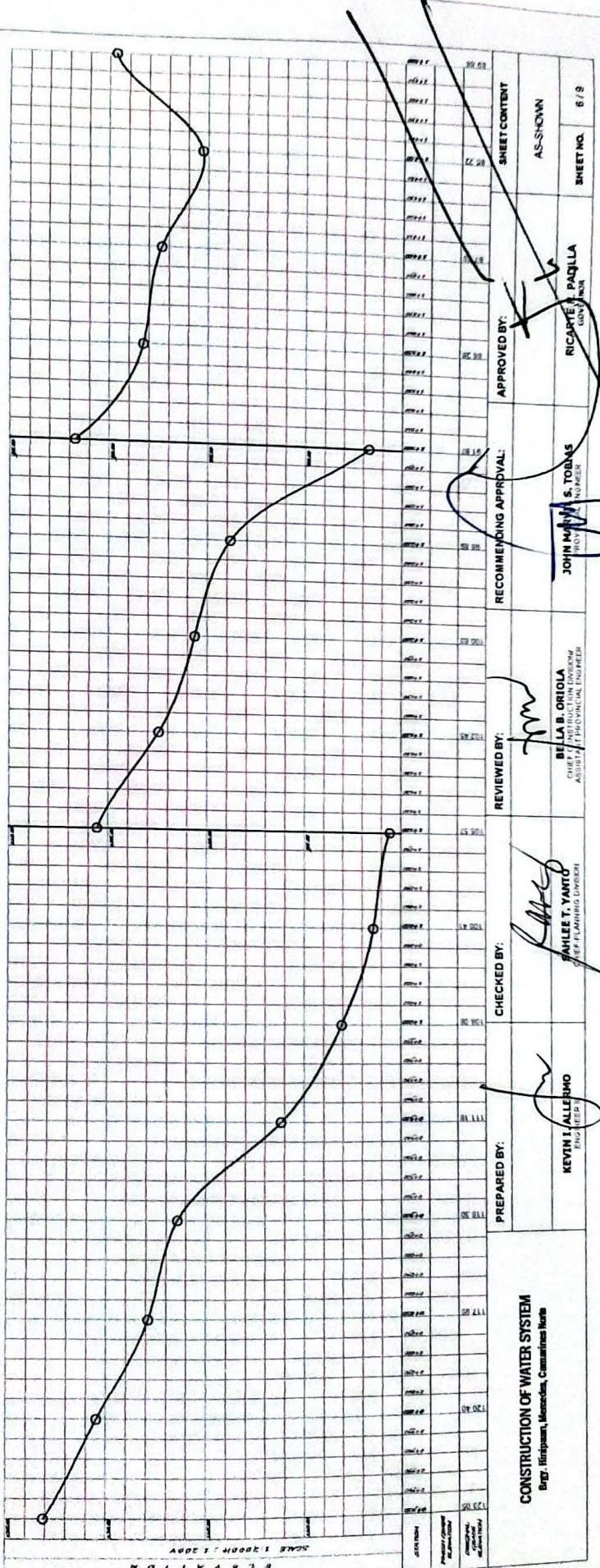
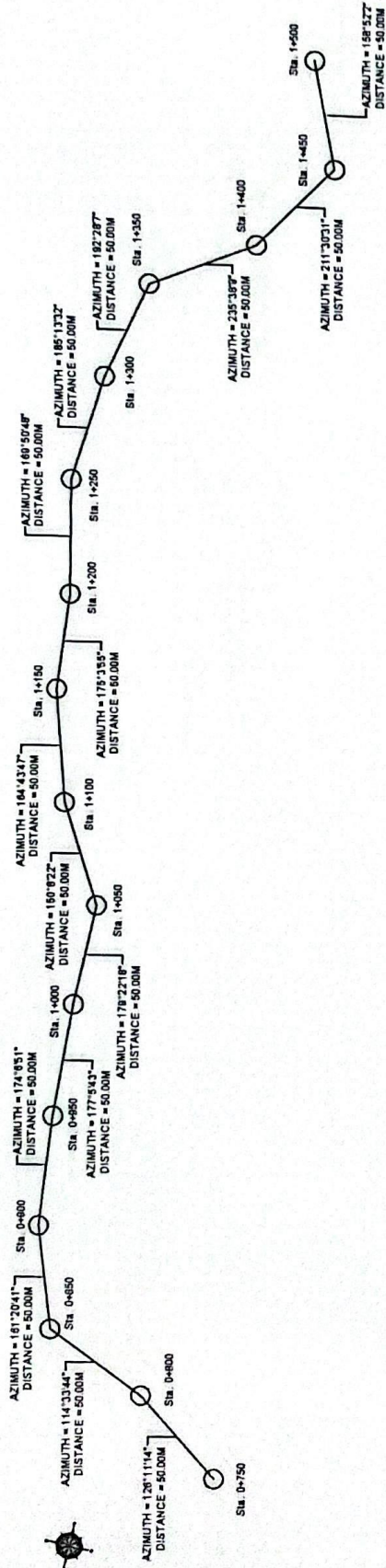

STATION	ELEVATION	REMARKS
Sta. 0+750	114.33	PIVOT POINT
Sta. 0+800	174.05	PIVOT POINT
Sta. 0+850	177.54	PIVOT POINT
Sta. 1+050	150.07	PIVOT POINT
Sta. 1+100	178.13	PIVOT POINT
Sta. 1+150	164.43	PIVOT POINT
Sta. 1+200	185.13	PIVOT POINT
Sta. 1+250	189.50	PIVOT POINT
Sta. 1+300	182.28	PIVOT POINT
Sta. 1+350	235.13	PIVOT POINT
Sta. 1+400	211.30	PIVOT POINT
Sta. 1+450	158.52	PIVOT POINT
Sta. 1+500	158.52	PIVOT POINT

PREPARED BY:	KEVIN I. ALLESMO PLANNING ENGINEER
CHECKED BY:	SAHLE T. YANTO PLANNING ENGINEER
REVIEWED BY:	BELLA B. ORIOLA PLANNING ENGINEER ASSISTANT PLANNING DIRECTOR
RECOMMENDING APPROVAL:	JOHN M. S. TORRES PLANNING ENGINEER
APPROVED BY:	RICARDO E. PAJILLA PLANNING ENGINEER

CONSTRUCTION OF WATER SYSTEM
 Proj. Itapipasa, Mercedes, Comarinas Area

SHEET CONTENT
 AS-SHOWN
 SHEET NO. 6 / 9

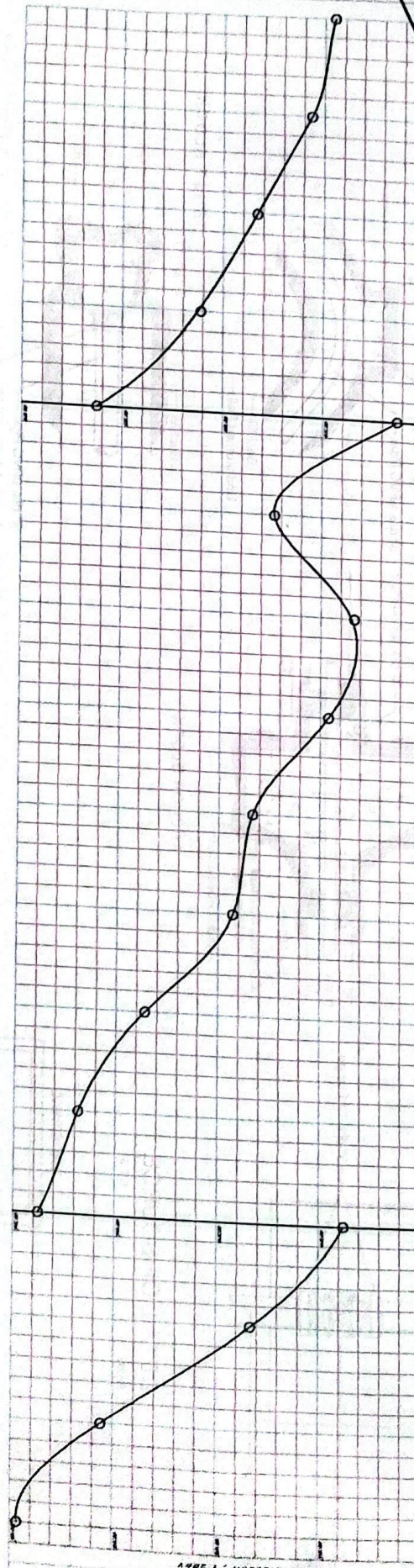
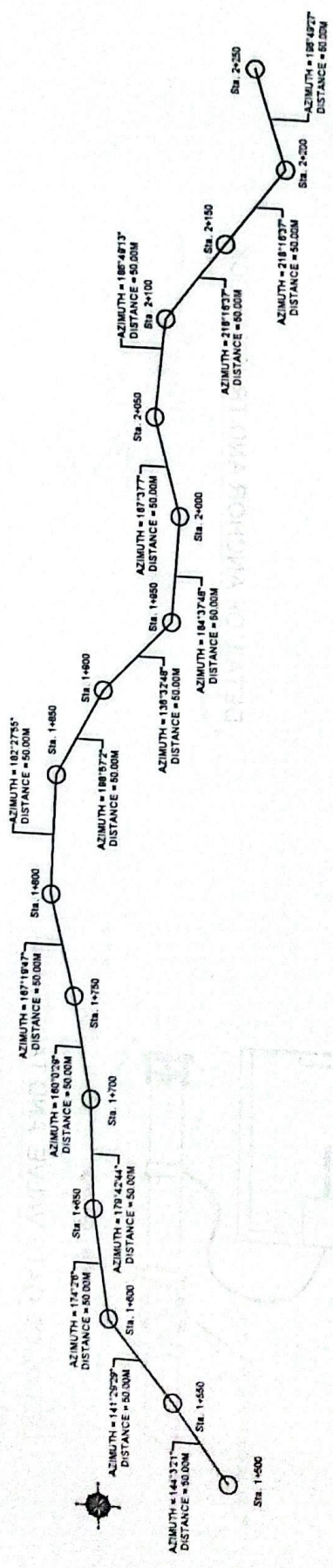

STATION	PROPOSED	EXISTING	REMARKS
Sta. 1+500			
Sta. 1+550			
Sta. 1+600			
Sta. 1+650			
Sta. 1+700			
Sta. 1+750			
Sta. 1+800			
Sta. 1+850			
Sta. 1+900			
Sta. 2+000			
Sta. 2+050			
Sta. 2+100			
Sta. 2+150			
Sta. 2+200			
Sta. 2+250			

APPROVED BY:	RECOMMENDING APPROVAL:	REVIEWED BY:	CHECKED BY:	PREPARED BY:
AS-SHOW	GOVERNOR	PROVINCIAL ENGINEER	CHIEF PLANNING DIVISION	ENGINEER
SHEET NO. 7/9				

CONSTRUCTION OF WATER SYSTEM
 Engr. Hirsipaan, Mercedes, Camarines Norte

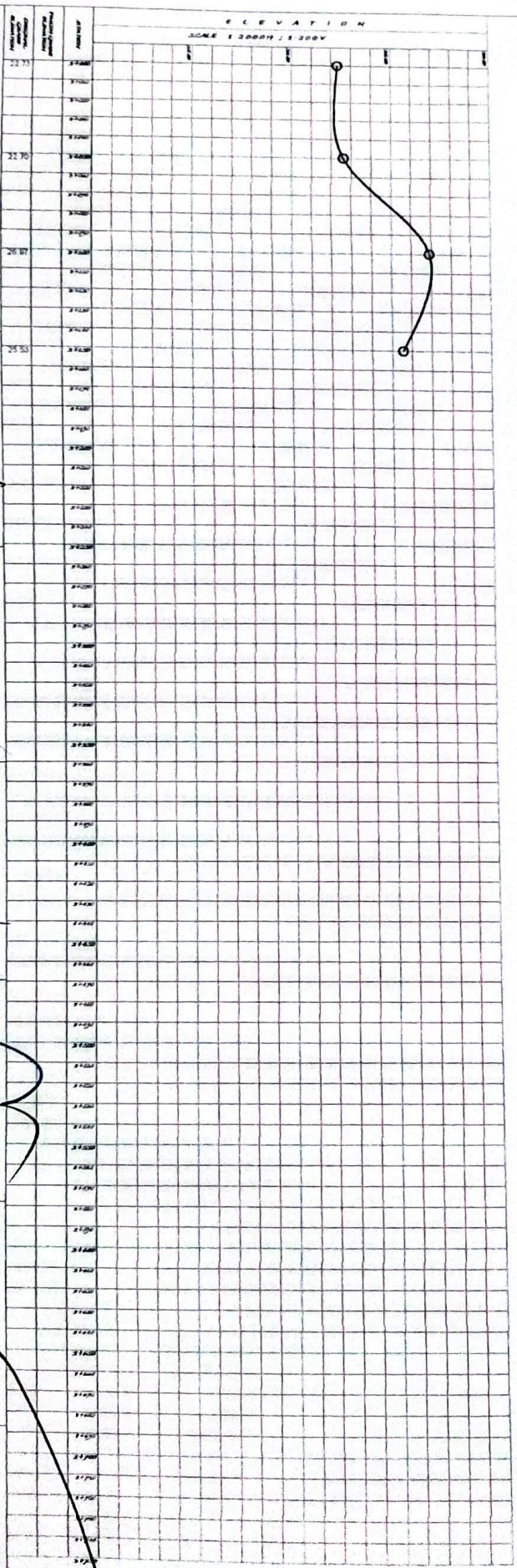
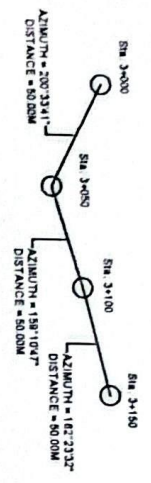

CONSTRUCTION OF WATER SYSTEM Dist. Hydrograph, Marikina, Cavite/Manila		PREPARED BY:	CHECKED BY:	REVIEWED BY:	RECOMMENDING APPROVAL:	APPROVED BY:	SHEET CONTENT
		KEVIN I. ALLENJO ENGINEER II	SAULET T. YAMBO CHIEF PLANNING DIVISION	BELA B. ORTOLA CHIEF CONSTRUCTION DIVISION/ ASSISTANT PROVINCIAL ENGINEER	JOHN MARCEL S. TORANS PROVINCIAL ENGINEER	RICARTE R. PADILLA GOVERNOR	AS-SHOWN SHEET NO. 9 / 9